

July 2014

MULTI-DEGREE SMOOTHER FOR LOW POWER TESTABLE DIGITAL SYSTEM DESIGN USING BS-LFSR AND SCAN-CHAIN ORDERING TECHNIQUES

V. SURYANARAYANA

Dept. of E.C.E, Sir C.R.REDDY College of Engineering, Eluru, v.surya256@gmail.com

K. MIRANJI

Dept. of E.C.E, Sir C.R.REDDY College of Engineering, Eluru, miranji.k@gmail.com

Follow this and additional works at: <https://www.interscience.in/ijess>



Part of the [Electrical and Electronics Commons](#)

Recommended Citation

SURYANARAYANA, V. and MIRANJI, K. (2014) "MULTI-DEGREE SMOOTHER FOR LOW POWER TESTABLE DIGITAL SYSTEM DESIGN USING BS-LFSR AND SCAN-CHAIN ORDERING TECHNIQUES," *International Journal of Electronics Signals and Systems*: Vol. 4 : Iss. 1 , Article 4.

Available at: <https://www.interscience.in/ijess/vol4/iss1/4>

This Article is brought to you for free and open access by Interscience Research Network. It has been accepted for inclusion in International Journal of Electronics Signals and Systems by an authorized editor of Interscience Research Network. For more information, please contact sritampatnaik@gmail.com.

MULTI-DEGREE SMOOTHER FOR LOW POWER TESTABLE DIGITAL SYSTEM DESIGN USING BS-LFSR AND SCAN-CHAIN ORDERING TECHNIQUES

V.SURYANARAYANA¹, K.MIRANJI²

¹M. Tech VLSI Design, ²M. Tech, Assistant Professor, Dept. of E.C.E, Sir C.R.REDDY College of Engineering, Eluru

Abstract- Testing of digital VLSI circuits entails many challenges as a consequence of rapid growth of semiconductor manufacturing technology and the unprecedented levels of design complexity and the gigahertz range of operating frequencies. These challenges include keeping the average and peak power dissipation and test application time within acceptable limits. This dissertation proposes techniques to address these challenges during test. The first proposed technique, called bit-swapping LFSR (BS-LFSR), uses new observations concerning the output sequence of an LFSR to design a low-transition test-pattern-generator (TPG) for test-per-clock built-in self-test (BIST) to achieve reduction in the overall switching activity in the circuit-under-test (CUT). The obtained results show up to 28% power reduction for the proposed design, and up-to 63% when it is combined with another established technique. The proposed BS-LFSR is then extended for use in test-per-scan vectors show up to 60% reduction in average power consumption. The BS-LFSR is then extended further to act as a multi-degree smoother for test patterns generated by conventional LFSRs before applying them to the CUT. Experimental results show up to 55% reduction in average power. Another technique that aims to reduce peak power in scan-based BIST is presented. The new technique uses a two-phase scan-chain ordering algorithm to reduce average and peak power in scan and capture cycles. Experimental results show up to 65% and 55% reduction in average and peak power, respectively. Finally, a technique that aims to significantly increase the fault coverage in test-Per scan BIST, while keeping the test-application time short, is proposed. The results obtained show a significant improvement in fault coverage and test application time compared with other techniques.

Keywords- Built-in self-test (BIST), linear feedback shift register (LFSR), low-power test, pseudorandom pattern generator, scan-chain ordering, weighted switching activity (WSA).

I. INTRODUCTION

In recent years, the design for low power has become one of the greatest challenges in high-performance very large scale integration (VLSI) design. As a consequence, many techniques have been introduced to minimize the power consumption of new VLSI systems. However, most of these methods focus on the power consumption during normal mode operation, while test mode operation has not normally been a predominant concern. However, it has been found that the power consumed during test mode operation is often much higher than during normal mode operation. This is because most of the consumed power results from the switching activity in the nodes of the circuit under test (CUT), which is much higher during test mode than during normal mode operation [1]-[3]. Several techniques that have been developed to reduce the peak and average power dissipated during scan-based tests can be found in [4] and [5]. A direct technique to reduce power consumption is by running the test at a slower frequency than that in normal mode. This technique of reducing power consumption, while easy to implement, significantly increases the test application time [6]. Furthermore, it fails in reducing peak-power consumption since it is independent of clock frequency. Another category of techniques used to reduce the power consumption in scan-based built-in self-tests (BISTs) is by using scan-chain-ordering techniques [7]-[13].

These techniques aim to reduce the average-power consumption when scanning in test vectors and scanning out captured responses. Although these algorithms aim to reduce average-power consumption, they can reduce the peak power that may occur in the CUT during the scanning cycles, but not the capture power that may result during the test cycle (i.e., between launch and capture). The design of low-transition test-pattern generators (TPGs) is one of the most common and efficient techniques for low-power tests [14]-[20]. These algorithms modify the test vectors generated by the LFSR to get test vectors with a low number of transitions. The main drawback of these algorithms is that they aim only to reduce the average-power consumption while loading a new test vector, and they ignore the power consumption that results while scanning out the captured response or during the test cycle. reduce average-power consumption, they can reduce the peak power that may occur in the CUT during the scanning cycles, but not the capture power that may result during the test cycle (i.e., between launch and capture). The design of low-transition test-pattern generators (TPGs) is one of the most common and efficient techniques for low-power tests [14]-[20]. These algorithms modify the test vectors generated by the LFSR to get test vectors with a low number of transitions. The main drawback of these algorithms is that they aim only to reduce the average-power consumption while loading a new test vector, and they ignore the power consumption that results while scanning out the captured response or

during the test cycle. Furthermore, some of these techniques may result in lower fault coverage and higher test-application time. Other techniques to reduce average-power consumption during scan-based tests include scan segmentation into multiple scan chains [6], [21], test-scheduling techniques [22], [23], static-compaction techniques [24], and multiple scan chains with many scan enable inputs to activate one scan chain at a time [25]. The latter technique also reduces the peak power in the CUT. On the other hand, in addition to the techniques mentioned earlier, there are some new approaches that aim to reduce peak-power consumption during tests, particularly the capture power in the test cycle.

One of the common techniques for this purpose is to modify patterns using an X-filling technique to assign values to the don't care bits of a deterministic set of test vectors in such a way as to reduce the peak power in the test vectors that have a peak-power violation [26]-[29]. This paper presents a new TPG, called the bit-swapping linear feedback shift register (BS-LFSR), that is based on a simple bit-swapping technique applied to the output sequence of a conventional LFSR and designed using a conventional LFSR and a 2×1 multiplexer. The proposed BS-LFSR reduces the average and instantaneous weighted switching activity (WSA) during test operation by reducing the number of transitions in the scan input of the CUT. The BS-LFSR is combined with a scan-chain-ordering algorithm that reduces the switching activity in both the test cycle (capture power) and the scanning cycles (scanning power).

II. PROPOSED APPROACH TO DESIGN THE BS-LFSR

The proposed BS-LFSR for test-per-scan BISTs is based upon some new observations concerning the number of transitions produced at the output of an LFSR. Definition: Two cells in an n -bit LFSR are considered to be adjacent if the output of one cell feeds the input of the second directly (i.e., without an intervening XOR gate). Lemma 1: Each cell in a maximal-length n -stage LFSR (internal or external) will produce a number of transitions equal to 2^{n-1} after going through a sequence of 2^n clock cycles.

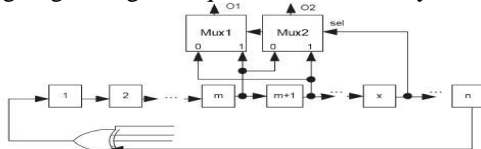

Fig. 1. Swapping arrangement for an LFSR.

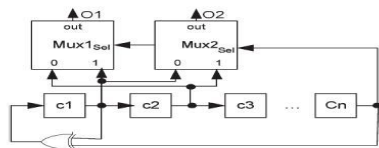

Fig. 2. External LFSR that implements the prime polynomial $x^n + x + 1$ and the proposed swapping arrangement.

Proof: The sequence of 1s and 0s that is followed by one bit position of a maximal-length LFSR is commonly referred to as an m -sequence. Each bit within the LFSR will follow the same m -sequence with a one-time-step delay. The m -sequence generated by an LFSR of length n has a periodicity of $2^n - 1$. It is a well-known standard property of an m -sequence of length n that the total number of runs of consecutive occurrences of the same binary digit is 2^{n-1} [3], [30]. The beginning of each run is marked by a transition between 0 and 1; therefore, the total number of transitions for each stage of the LFSR.

2^{n-1} . This lemma can be proved by using the toggle property of the XOR gates used in the feedback of the LFSR [32]. Lemma 2: Consider a maximal-length n -stage internal or external LFSR ($n > 2$). We choose one of the cells and swap its value with its adjacent cell if the current value of a third cell in the LFSR is 0 (or 1) and leave the cells unswapped if the third cell has a value of 1 (or 0). Fig. 1 shows this arrangement for an external LFSR (the same is valid for an internal LFSR). In this arrangement, the output of the two cells will have its transition count reduced by $T_{\text{saved}} = 2^{(n-2)}$ transitions. Since the two cells originally produce $2 \times 2^{n-1}$ transitions, then the resulting percentage saving is $T_{\text{saved}\%} = 25\%$ [32]. In Lemma 2, the total percentage of transition savings after swapping is 25% [31]. In the case where cell x is not directly linked to cell m or cell $m + 1$ through an XOR gate, each of the cells has the same share of savings (i.e., 25%).

Lemmas 3-10 show the special cases where the cell that drives the selection line is linked to one of the swapped cells through an XOR gate. In these configurations, a single cell can save 50% transitions that were originally produced by an LFSR cell. Lemma 3 and its proof are given; other lemmas can be proved in the same way. Lemma 3: For an external n -bit maximal-length LFSR that implements the prime polynomial $x^n + x + 1$ as shown in Fig. 2, if the first two cells (c_1 and c_2) have been chosen for swapping and cell n as a selection line, then o_2 (the output of MUX2) will produce a total transition savings of 2^{n-2} compared to the number of transitions produced by each LFSR cell, while o_1 has no savings (i.e., the savings in transitions is concentrated in one multiplexer output, which means that o_2 will save 50% of the original transitions produced by each LFSR cell). Proof:

There are eight possible combinations for the initial state of the cells c_1 , c_2 , and c_n . If we then consider all possible values of the following state, we have two possible combinations (not eight, because the value of c_2 in the next state is determined by the value of c_1 in the present state; also, the value of c_1 in the next state is determined by $\neg c_1 \text{ xor } c_n$ in the present state). Table I shows all possible and subsequent states.

It is important to note that the overall savings of 25% is not equally distributed between the outputs of the multiplexers as in Lemma 2.

This is because the value of c_1 in the present state will affect the value of c_2 and its own value in the next state ($c_{2(Next)} = c_1$ and $c_{1(Next)} = \neg c_1 \text{ xor } c_n$).

TABLE I
POSSIBLE AND SUBSEQUENT STATES FOR CELLS $c_1, c_2,$ AND c_n
(SEE FIG. 2)

LFSR outputs of m, m+1						Multiplexers outputs O_1, O_2									
States			Next states			transition			states		Next States		transition		
c_1	c_2	c_n	c_1	c_2	c_n	c_1	c_2	Σ	O_1	O_2	O_1	O_2	O_1	O_2	Σ
0	0	0	0	0	0	0	0	0	0	0	0	0	0	0	0
			0	0	1	0	0	0	0	0	0	0	0	0	0
			1	0	0	1	0	1	0	0	0	1	0	1	1
			1	0	1	1	0	1	0	0	1	0	1	0	1
0	1	0	0	0	0	0	1	1	1	0	0	0	1	0	1
			0	0	1	0	1	1	1	0	0	0	1	0	1
0	1	1	1	0	0	1	1	2	0	1	0	1	0	0	0
			1	0	1	1	1	2	1	0	1	1	1	2	2
1	0	0	1	1	0	0	1	1	0	1	1	1	0	1	1
			1	1	1	0	1	1	1	1	1	1	0	1	1
1	0	1	0	1	0	1	1	2	1	0	0	0	0	0	0
			0	1	1	1	1	2	0	1	1	1	1	2	2
1	1	0	1	1	0	0	0	0	1	1	1	0	0	0	0
			1	1	1	0	0	0	1	1	1	0	0	0	0
1	1	1	0	1	0	1	0	1	1	1	0	0	1	1	1
			0	1	1	1	0	1	0	1	1	0	1	1	1
Σ Transitions			8	8	16						8	4	12		

To see the effect of each cell in transition savings, Table I shows that o_1 will save one transition when moving from state (0,0,1) to (1,0,0), from (0,1,1) to (1,0,0), from (1,0,1) to (0,1,0), or from (1,1,1) to (0,1,0). In the same time, o_1 will increase one transition when moving from (0,1,0) to (0,0,0), from (0,1,0) to (0,0,1), from (1,0,0) to (1,1,0), or from (1,0,0) to (1,1,1).

Since o_1 increases the transitions in four possible scenarios and save transitions in other four scenarios, then it has a neutral overall effect because all the scenarios have the same probabilities. For o_2 , one transition is saved when moving from (0,1,0) to (0,0,0), from (0,1,0) to (0,0,1), from (0,1,1) to (1,0,0), from (1,0,0) to (1,1,0), from (1,0,0) to (1,1,1), or from (1,0,1) to (0,1,0). At the same time, one additional transition is incurred when moving from state (0,0,1) to (1,0,0) or from (1,1,1) to (0,1,0).

This gives o_2 an overall saving of one transition in four possible scenarios where the initial states has a probability of 1/8 and the final states of probability 1/2; hence, P_{save} is given by $P_{save} = 1/8 \times 1/2 + 1/8 \times 1/2 + 1/8 \times 1/2 + 1/8 \times 1/2 = 1/4$. (1)

TABLE II
SPECIAL CASES WHERE ONE CELL SAVES 50% OF THE TRANSITIONS

Lemmas	LFSR Polynomial	LFSR Type	Swapped cells		Selection Line	MUX Out 50% Save
			1 st	2 nd		
Lemma 3	x^3+x+1	External	C_1	C_2	C_n	O_2
Lemma 4	x^3+x+1	Internal	C_1	C_n	C_2	O_2
Lemma 5	$x^n+x^{n-1}+1$	External	C_{n-1}	C_n	C_1	O_1
Lemma 6	$x^n+x^{n-1}+1$	Internal	C_1	C_n	C_{n-1}	O_1
Lemma 7	x^6+x^2+1	External	C_1	C_2	C_n	O_1
Lemma 8	$x^n+x^{n-2}+1$	Internal	C_{n-1}	C_n	C_{n-2}	O_1
Lemma 9	$x^n+x^{n-1}+x^{2m}+x^{2m+1}+x^{2l}+x^{2l+1}+1$	Internal	C_1	C_n	C_{n-1}	O_1
Lemma 10	$x^n+x^{n-2}+x^{2m}+x^{2m+1}+x^{2l}+x^{2l+1}+1$	Internal	C_{n-1}	C_n	C_{n-2}	O_1

TABLE III
LFSRS THAT SATISFY ONE OR MORE OF LEMMAS 3-10

# of LFSR Stages	LFSR settle one or more of Lemmas 3 to 10 in table 2
3-20	3, 4, 5, 6, 7, 8, 11, 12, 13, 14, 15, 16, 19
21-40	21, 22, 24, 26, 27, 29, 30, 32, 34, 35, 37, 38, 40
41-60	42, 43, 44, 45, 46, 48, 50, 51, 53, 54, 56, 59, 60
61-80	61, 62, 63, 64, 66, 67, 69, 70, 74, 75, 76, 77, 78, 80
81-100	83, 85, 86, 88, 90, 91, 92, 93, 96, 99
101-120	101, 102, 104, 107, 109, 110, 112, 114, 115, 116, 117
121-140	122, 123, 125, 126, 127, 128, 131, 133, 136, 138
141-160	141, 143, 144, 146, 147, 149, 152, 153, 154, 155, 156, 157, 158, 160
161-168	162, 163, 164, 165, 166, 168
Total	104

If the LFSR is allowed to move through a complete cycle of 2^n states, then Lemma 1 shows that the number of transitions expected to occur in the cell under consideration is 2^{n-1} . Using the swapping approach, in 1/4 of the cases, a saving of one transition will occur, giving a total saving of $1/4 \times 2^n = 2^{n-2}$. Dividing one figure by the other, we see that the total number of transitions saved at o_2 is 50%. In the special configurations shown in Table II (i.e. Lemmas 3-10), if the cell that saves 50% of the transitions is connected to feed the scan-chain input, then it saves 50% of the transitions inside the scan-chain cells, which directly reduces the average power and also the peak power that may result while scanning in a new test vector. Table III shows that there are 104 LFSRs (internal and external) whose sizes lie in the range of 3-168 stages that can be configured to satisfy one or more of the special cases in Table II to concentrate the transition savings in one multiplexer output.

III. IMPORTANT PROPERTIES OF THE BS-LFSR

There are some important features of the proposed BS-LFSR that make it equivalent to a conventional LFSR. The most important properties of the BS-LFSR are the following. 1) The proposed BS-LFSR generates the same number of 1s and 0s at the output of multiplexers after swapping of two adjacent cells; hence, the probabilities of having a 0 or 1 at a certain cell of the scan chain before applying the test vectors are equal. Hence, the proposed design retains an important feature of any random TPG. Furthermore, the output of the multiplexer depends on three

different cells of the LFSR, each of which contains a pseudorandom value. Hence, the expected value at the output can also be considered to be a pseudorandom value. 2) If the BS-LFSR is used to generate test patterns for either test-per-clock BIST or for the primary inputs of a scan-based sequential circuit (assuming that they are directly accessible) as shown in Fig. 3, then consider the case that c_1 will be swapped with c_2 and c_3 with c_4, \dots, c_{n-2} with c_{n-1} according to the value of c_n which is connected to the selection line of the multiplexers (see Fig. 3). In this case, we have the same exhaustive set of test vectors as would be generated by the conventional LFSR, but their order will be different and the overall transitions in the primary inputs of the CUT will be reduced by 25% [32].

IV. CELL REORDERING ALGORITHM

Although the proposed BS-LFSR can achieve good results in reducing the consumption of average power during test and also in minimizing the peak power that may result while scanning a new test vector, it cannot reduce the overall peak power because there are some components that occur while scanning out the captured response or while applying a test vector and capturing a response in the test cycle. To solve these problems, first, the proposed BS-LFSR has been combined with a cell-ordering algorithm presented in [11] that reduces the number of transitions in the scan chain while scanning out the captured response.

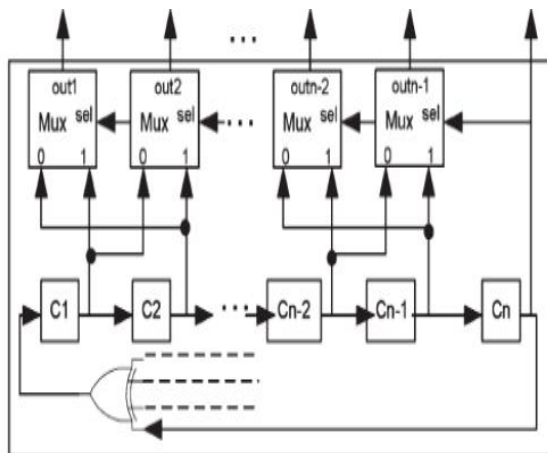

Fig. 3. BS-LFSR can be used to generate exhaustive patterns for test-per-clock BIST.

This will reduce the overall average power and also the peak power that may arise while scanning out a captured response. The problem of the capture power (peak power in the test cycle) will be solved by using a novel algorithm that will reorder some cells in the scan chain in such a way that minimizes the Hamming distance between the applied test vector and the captured response in the test cycle, hence

reducing the test cycle peak power (capture power). In this scan-chain-ordering algorithm, some cells of the ordered scan chain using the algorithm in [11] will be reordered again in order to reduce the peak power which may result during the test cycle. This phase mainly depends on an important property of the BS-LFSR. This property states that, if two cells are connected with each other, then the probability that they have the same value at any clock cycle is 0.75. (In a conventional LFSR where the transition probability is 0.5, two adjacent cells will have the same value in 50% of the clocks and different values in 50% of the clocks; for a BS-LFSR that reduces the number of transition of an LFSR by 50%, the transition probability is 0.25, and hence, two adjacent cells will have the same value in 75% of the clock cycles.) Thus, for two connected cells (cells j and k), if we apply a sufficient number of test vectors to the CUT, then the values of cells j and k are similar in 75% of the applied vectors.

Hence, assume that we have cell x which is a function of cells y and z . If the value that cell x will have in the captured response is the same as its value in the applied test vector (i.e., no transition will happen for this cell in the test cycle) in the majority of cases where cells y and z have the same value, then we connect cells y and z together on the scan chain, since they will have the same value in 75% of the cases.

This reduces the possibility that cell x will undergo a transition in the test cycle. The steps in this algorithm are as follows. 1) Simulate the CUT for the test patterns generated by the BS-LFSR. 2) Identify the group of vectors and responses that violate the peak power. 3) In these vectors, identify the cells that mostly change their values in the test cycle and cause the peak-power violation. 4) For each cell found in step 3), identify the cells that play the key role in the value of this cell in the test cycle. 5) If it is found that, when two cells have a similar value in the applied test vector, the concerned cell will most probably have no transition in the test cycle, then connect these cells together. If it is found that, when two cells have a different value, the cell under consideration will most probably have no transitions in the test cycle, then connect these cells together through an inverter.

It is important to note that this phase of ordering is done when necessary only, as stated in step 2 of the algorithm description that the group of test vectors that violates the peak power should be identified first. Hence, if no vector violates the peak power, then this phase will not be done. In the worst case, this phase is performed in few subsets of the cells. This is because, if this phase of ordering is done in all cells of the scan chain, then it will destroy the effect of algorithm found in [11] and will substantially increase the computation time.

TABLE IV
TEST LENGTH NEEDED TO GET TARGET FAULT COVERAGE FOR LFSR AND BS-LFSR

Circuit	n	m	PI	RF%	FC%	Test Length			
						Det.	LFSR	BS-LFSR no order	BS-LFSR with order
S641	32	19	35	0	98.0	53	5120	4910	4970
S838	32	32	35	0	86.5	90	8160	8460	7910
S1196	30	18	14	0	97.0	131	3750	3680	3370
S1238	30	18	14	5.09	91.3	141	3890	3560	3610
S5378	40	179	35	0.88	98.0	244	30110	33700	28900
S9234	40	228	19	6.52	90.0	367	397800	401930	398170
S13207	60	669	31	1.54	95.0	455	49660	47400	48110
S35932	64	1728	35	10.19	89.8	63	18700	16640	16520
S38417	64	1636	28	0.53	96.5	849	118580	125520	117080
S38584	64	1452	12	4.15	94	632	43530	39660	40090

TABLE V
EXPERIMENTAL RESULTS OF AVERAGE- AND PEAK-POWER REDUCTION OBTAINED BY USING THE PROPOSED TECHNIQUES

Circuit	TL	LFSR			BS-LFSR with cell ordering			%Savings of BS-LFSR	
		FC%	WSA _{avg}	WSA _{pk}	FC%	WSA _{avg}	WSA _{pk}	WSA _{av}	WSA _{pk}
S641	3000	97.84	97.78	153	97.54	42.20	84	57	45
S838	20000	96.15	81.91	151	96.21	33.14	83	60	45
S1196	2000	95.33	53.18	74	95.51	21.52	42	60	43
S1238	3000	91.11	61.20	97	90.97	34.80	59	43	39
S5378	40000	98.42	1143.24	1639	98.40	625.28	993	45	39
S9234	100000	87.27	2817.45	3988	87.28	1108.93	2197	61	45
S13207	100000	96.45	4611.67	7108	96.39	1897.33	4172	59	41
S35932	200	87.88	7945.81	12592	87.89	2793.16	5723	65	55
S38417	100000	95.73	10965.50	16380	95.68	5022.30	10017	54	39
S38584	100000	94.46	11194.65	15974	94.48	5682.72	7851	49	51

V. EXPERIMENTAL RESULTS

A group of experiments was performed on full-scan ISCAS'89 benchmark circuits. In the first set of experiments, the BS-LFSR is evaluated regarding the length of the test sequence needed to achieve a certain fault coverage with and without the scan-chain-ordering algorithm. Table IV shows the results for a set of ten benchmark circuits. The columns labeled n, m, and PI refer to the sizes of the LFSR, the number of flip-flops in the scan chain, and the number of primary inputs of the CUT, respectively. The column labeled RF indicates the percentage of redundant faults in the CUT, and fault coverage (FC) indicates the target fault coverage where redundant faults are included. The last four columns show the test length needed by a deterministic test (i.e., the optimal test vector set is stored in a ROM), a conventional LFSR, a BS-LFSR with no scan-chain ordering, and the BS-LFSR with scan-chain ordering, respectively. The results in Table IV show that the BS-LFSR needs a shorter test length than a conventional LFSR for many circuits even without using the scan-chain-ordering algorithm. It also shows that using the scan-chain-ordering algorithm with BS-LFSR will shorten the required test length. The second set of experiments is used to evaluate the BS-LFSR together with the proposed scan-chain-ordering algorithm in reducing average and peak power. For each benchmark circuit, the same numbers of conventional LFSR and BS-LFSR patterns are applied to the full scan configuration. Table V shows the obtained results for the same

benchmark circuits as in Table IV. The column labeled test length (TL) refers to the number of test vectors applied to the CUT. The next three columns show the FC, average WSA per clock cycle.

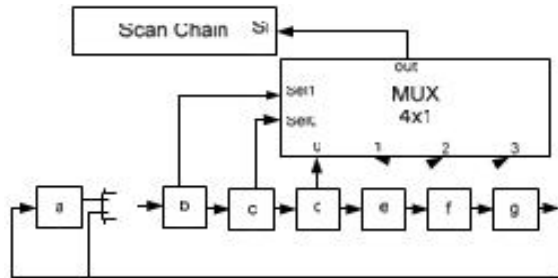

Figure 4: 7-bit internal LFSR with 4x1 multiplexer to get a smoothing degree $k=2$

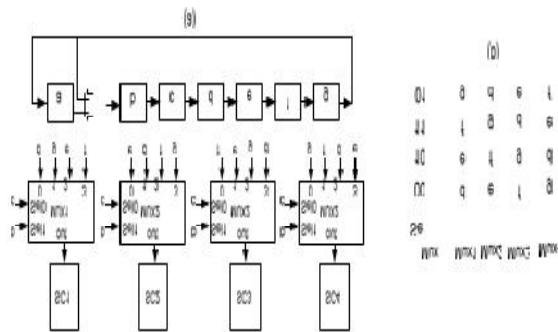

Figure 5. Extending the smoothing technique for multiple scan-chains, (b) the rotational property of the proposed design.

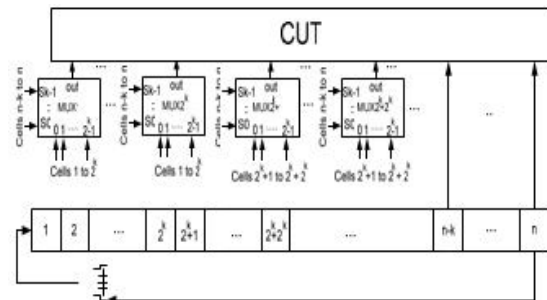

Figure 6: The Architecture of the RLFSR for test-per-clock BIST

TABLE VI
COMPARISON WITH RESULTS OBTAINED IN [15]

Circuit	Results in [15]			Results of proposed method		
	TL	FC	%WSA _{av}	TL	FC	%WSA _{av}
S641	4096	97.21	38	3000	97.54	57
S838	4096	95.46	50	20000	96.21	60
S1196	4096	95.59	17	2000	95.51	60
S1238	4096	89.41	17	3000	90.97	43
S5378	65536	96.54	43	40000	98.40	45
S9234	524288	90.89	62	100000	87.28	61
S13207	132072	93.66	45	100000	96.39	59
S35932	128	87.84	56	200	87.89	65
S38417	132072	94.99	56	100000	95.68	54
S38584	132072	93.35	59	100000	94.48	49
AVG	100255	93.49	44	46820	94.04	55

TABLE VII
COMPARISON OF PEAK-POWER REDUCTIONS WITH RESULTS IN [25]

Circuit	Results in [25]		Proposed Method	
	WSA _{pk}	Savings %	WSA _{pk}	Savings %
S5378	36.6		39	
S9234	38.9		45	
S13207	46.1		41	
S38417	40.1		39	
S38584	35.9		51	
AVG	39.5		43.0	

(WSAavg), and the maximum WSA in a clock cycle (WSApeak) for patterns applied using the conventional LFSR. The next three columns show FC, WSAavg, and WSApeak for the BS-LFSR with ordered scan chain. Finally, the last two columns show the savings in average and peak power by using the BS-LFSR with the scan-chain-ordering algorithm. In order to provide a comparison with the techniques published previously by other authors, Table VI compares the results obtained by the proposed technique with those obtained in [15].

Table VI compares the TL, FC, and average-power reduction (WSAavg). It is clear that the proposed method is much better for most of the circuits, not only in average-power reduction but also in the test length needed to obtain good fault coverage. Finally, Table VII compares the results obtained by the proposed technique for peak-power reduction with those obtained in [25]. It is clear from the table that the proposed method has better results for most of the benchmark circuits.

VII. SIMULATION RESULTS

Scan Cell Re ordering Algorithm : In this Fig .4, FF1-FF3-FF2 represents the flip flops which are used to reordering itself defined in the coding by using this technique only to reduce the number of transitions (when we give four inputs to the test vector, it reduces the number of transitions by using Scan Cell Re order module. In this way we are reducing some amount of wastage of power.

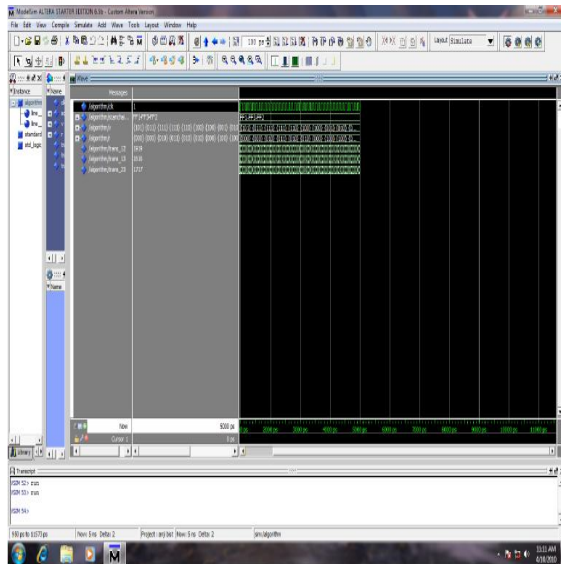

Fig. 4. Scan Cell re ordering Algorithm

BS-LFSR Algorithm: When inputs are clk= clk ,rst=1 and lfsr init=0001 ,Once it is run ,the reset value should be changed to RST=0 . Then output waveform is shown in the Fig.5, By using this method, the remaining wastage of power can be eliminated.

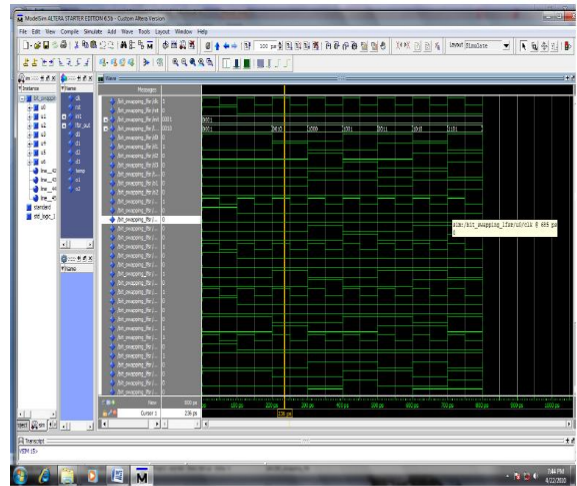

Fig.5. BS-LFSR Algorithm

Final Module: When inputs are clk =clk and rst=1 initial values= 1010, then once it is run , reset value must be changed to zero, In this we insert fault in the practical circuit(s27_f) circuit that is a6=b6(code). Then outputs are z=1(S27 ckt) output of the sequential circuit and(S27_f ckt out put) z_f=1 means in s27_f circuit fault is there that why it represents it as =1 is shown in Fig.8. Now Fig.7. Screen shot represents fault less that is in practical circuit (s27_f) a6=a6 (fault free) only when there is no fault we have save that and run and we get OUTPUT z_f=0 . It represents No fault.

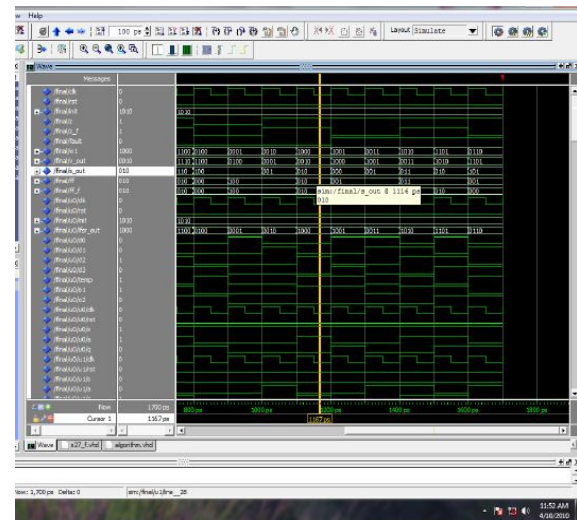

Fig.7. Fault free Final Module

VII. CONCLUSION AND FUTURE WORK

The increasing demand for portable electronic devices with long lifetime battery and reliable functionality has led to increased interest in low power design. However, many faults may arise in digital circuits either during fabrication or during operational lifetime. If these faults remain undetected, then there is no way to distinguish good chips from

faulty chips. Hence, test is a necessary part of the manufacturing process. However, it is found that the power consumption during test is higher than during normal operation. Thus, it is very important to develop techniques for low power testing. On the other hand, in order for testing to be a reliable and cost-efficient process, it should detect all or most of the faults (stuck-at-faults on this thesis) that may occur in digital circuits within an acceptable test length (and, therefore, test application time) and acceptable storage space. Hence, deterministic tests (which store test vectors in memory) are not the optimal solution since they need a huge storage space for large circuits. However, random TPGs are not good since there are some faults (known as random pattern resistant faults) that need a very long sequence of test vectors (i.e. an extremely long test application time). Thus, it is very important to produce techniques that compromise between hardware overhead, test application time, and the obtained fault coverage.

1. Average Power Minimization in Test-per-Clock BIST using Low Transition LFSR
2. Average Power Minimization in Test-per-Scan BIST using Low Transition LFSR
3. Scan and Capture Peak Power Minimization in Scan-Based BIST using BS-LFSR, and 2-Phase Scan-Chain Ordering Algorithm
4. Increasing Fault Coverage in Scan-Based BIST using a Multi-Output LFSR

FUTURE WORK

1. Investigation of LFSRS' Properties
2. Random memory access test
3. System-on-a-chip (soc) memory test
4. Low power delay test

REFERENCES

- [1] Y. Zorian, —A distributed BIST control scheme for complex VLSI devices, □ in Proc. 11th IEEE VTS, Apr. 1993, pp. 4-9.
- [2] A. Hertwig and H. J. Wunderlich, —Low power serial built-in self-test, □ in Proc. IEEE Eur. Test Workshop, May 1998, pp. 49-53.
- [3] P. H. Bardell, W. H. McAnney, and J. Savir, Built-in Test for VLSI: Pseudorandom Techniques. New York: Wiley, 1997.
- [4] P. Girard, —Survey of low-power testing of VLSI circuits, □ IEEE Des. Test Comput., vol. 19, no. 3, pp. 80-90, May/June 2002.
- [5] K. M. Butler, J. Saxena, T. Fryars, G. Hetherington, A. Jain, and J. Lewis, —Minimizing power consumption in scan testing: Pattern generation and DFT techniques, □ in Proc. Int. Test Conf., 2004, pp. 355-364.
- [6] Saxena, K. Butler, and L. Whetsel, —An analysis of power reduction techniques in scan testing, □ in Proc. Int. Test Conf. 2001 670-677.
- [7] V. Dabholkar, S. Chakravarty, I. Pomeranz, and S. M. Reddy, —Techniques for minimizing power dissipation in scan and combinational circuits during test applications, □ IEEE Trans. Comput.-Aided Design Integr. Circuits Syst., vol. 17, no. 12, pp. 1325-1333, Dec. 1998.
- [8] Y. Bonhomme, P. Girard, L. Guiller, C. Landrault, S. Pravossoudovitch, and V. Virazel, —Design of routing-constrained low power scan chains, □ in Proc. Des. Autom. Test Eur. Conf. Exhib., Feb. 2004, pp. 62-67.
- [9] W. Tseng, —Scan chain ordering technique for switching activity reduction during scan test, □ Proc. Inst. Elect. Eng.—Comput. Digit. Tech., vol. 152, no. 5, pp. 609-617, Sep. 2005.
- [10] C. Giri, B. Kumar, and S. Chattopadhyay, —Scan flip-flop ordering with delay and power minimization during testing, □ in Proc. Annu. IEEE INDICON, Dec. 2005, pp. 467-471.
- [11] Y. Bonhomme, P. Girard, C. Landrault, and S. Pravossoudovitch, —Power driven chaining of flip-flops in scan architectures, □ in Proc. Int. Test Conf., Oct. 2002, pp. 796-803.
- [12] M. Bellos, D. Bakalis, and D. Nikolos, —Scan cell ordering for low power BIST, □ in Proc. IEEE Comput. Soc. Annu. Symp. VLSI, Feb. 2004, pp. 281-284.
- [13] K. V.A. Reddy and S. Chattopadhyay, —An efficient algorithm to reduce test power consumption by scan cell and scan vector reordering, □ in Proc. IEEE 1st India Annu. Conf. INDICON, Dec. 2004, pp. 373-376.
- [14] S. Wang, —A BIST TPG for low power dissipation and high fault coverage, □ IEEE Trans. Very Large Scale Integr. (VLSI) Syst., vol. 15, no. 7, pp. 777-789, Jul. 2007.
- [15] S. Wang and S. Gupta, —LT-RTPG: A new test-per-scan BIST TPG for low switching activity, □ IEEE Trans. Comput.-Aided Design Integr. Circuits Syst., vol. 25, no. 8, pp. 1565-1574, Aug. 2006.
- [16] S. Wang and S. K. Gupta, —DS-LFSR: A BIST TPG for low switching activity, □ IEEE Trans. Comput.-Aided Design Integr. Circuits Syst., vol. 21, no. 7, pp. 842-851, Jul. 2002.
- [17] H. Ronghui, L. Xiaowei, and G. Yunzhan, —A low power BIST TPG design, □ in Proc. 5th Int. Conf. ASIC, Oct. 2003, vol. 2, pp. 1136-1139.
- [18] L. Jie, Y. Jun, L. Rui, and W. Chao, —A new BIST structure for low power testing, □ in Proc. 5th Int. Conf. ASIC, Oct. 2003, vol. 2, pp. 1183-1185.
- [19] M. Tehranipoor, M. Nourani, and N. Ahmed, —Low transition LFSR for BIST-based applications, □ in Proc. 14th ATS, Dec. 2005, pp. 138-143.
- [20] I. Pomeranz and S. M. Reddy, —Scan-BIST based on transition probabilities for circuits with single and multiple scan chains, □ IEEE Trans. Comput.-Aided Design Integr. Circuits Syst., vol. 25, no. 3, pp. 591-596, Mar. 2006.
- [21] N. Nicolici and B. Al-Hashimi, —Multiple scan chains for power minimization during test application in sequential circuits, □ IEEE Trans. Comput., vol. 51, no. 6, pp. 721-734, Jun. 2002.
- [22] V. Iyengar and K. Chakrabarty, —Precedence-based, preemptive, and power-constrained test scheduling for system-on-a-chip, □ in Proc. IEEE VLSI Test Symp., 2001, pp. 368-374.
- [23] R. Chou, K. Saluja, and V. Agrawal, —Power constraint scheduling of tests, □ in Proc. IEEE Int. Conf. VLSI Des., 1994, pp. 271-274.
- [24] R. Sankaralingam, R. Oruganti, and N. Touba, —Static compaction techniques to control scan vector power

- dissipation, □ in Proc. IEEE VLSI Test Symp., 2000, pp. 35-42.
- [25] S. Wang and W. Wei, —A technique to reduce peak current and average power dissipation in scan designs by limited capture, □ in Proc. Asia South Pacific Des. Autom. Conf., Jan. 2007, pp. 810-816.
- [26] N. Badereddine, P. Girard, S. Pravossoudovitch, C. Landrault, A. Virazel, and H. Wunderlich, —Minimizing peak power consumption during scan testing: Test pattern modification with X filling heuristics, □ in Proc. Des. Test Integr. Syst. Nanoscale Technol., 2006, pp. 359-364.
- [27] R. Sankaralingam and N. Touba, —Controlling peak power during scan testing, □ in Proc. 20th IEEE VLSI Test Symp., 2002, pp. 153-159.
- [28] S. Remersaro, X. Lin, S. M. Reddy, I. Pomeranz, and J. Rajski, —Low shift and capture power scan tests, □ in Proc. Int. Conf. VLSI Des., 2007, pp. 793-798.
- [29] X. Wen, Y. Yamashita, S. Kajihara, L. Wang, K. Saluja, and K. Kinoshita, —On low-capture-power test generation for scan testing, □ in Proc. 23rd IEEE VLSI Test Symp., 2005, pp. 265-270.
- [30] R. David, Random Testing of Digital Circuits, Theory and Applications. New York: Marcel Dekker, 1998.
- [31] A. Abu-Issa and S. Quigley, —LT-PRPG: Power minimization technique for test-per-scan BIST, □ in Proc. IEEE Int. Conf. DTIS, Mar. 2008, pp. 1-5.

- [32] A. Abu-Issa and S. Quigley, —Bit-swapping LFSR for low-power BIST, □ Electron. Lett., vol. 44, no. 6, pp. 401-402, Mar. 2008.



K. MIRANJI received the B.Tech degree in Electronics & communication from JNTU Hyderabad, India, in 2007, and the M.Tech degree in Embedded Systems from JNTU Kakinada in 2011. His research interests include low power computing, real time Embedded Systems, operating systems real time Embedded Systems, operating systems



Vardhineni Surya Narayana received the B.Tech degree in Electronics & communication from Bhimavaram Institute of Engineering and Technology affiliated to JNTU Kakinada University. Presently pursuing his M.Tech in VLSI SIR C.R. REDDY College of Engineering affiliated to AU University.

