

October 2013

A RAKE RECEIVER DESIGN FOR ULTRA WIDE BAND APPLICATION

SURAJIT DEKA

Dept. of Electronics and Communication Engineering, Gauhati University, Guwahati-14, Assam, India,
dekasurajit123@gmail.com

MANASH PRATIM SARMA

Dept. of Electronics and Communication Engineering, Gauhati University, Guwahati-14, Assam, India,
manashpelsc@gmail.com

Kandarpa Kumar Sarma

Department of Electronics and Communication Technology, Gauhati University, Guwahati, Assam-781014,
kandarpaks@gmail.com

Follow this and additional works at: <https://www.interscience.in/ijess>



Part of the [Electrical and Electronics Commons](#)

Recommended Citation

DEKA, SURAJIT; SARMA, MANASH PRATIM; and Sarma, Kandarpa Kumar (2013) "A RAKE RECEIVER DESIGN FOR ULTRA WIDE BAND APPLICATION," *International Journal of Electronics Signals and Systems*: Vol. 3 : Iss. 4 , Article 7.

Available at: <https://www.interscience.in/ijess/vol3/iss4/7>

This Article is brought to you for free and open access by Interscience Research Network. It has been accepted for inclusion in International Journal of Electronics Signals and Systems by an authorized editor of Interscience Research Network. For more information, please contact sritampatnaik@gmail.com.

A RAKE RECEIVER DESIGN FOR ULTRA WIDE BAND APPLICATION

SURAJIT DEKA¹, MANASH PRATIM SARMA² & KANDARPA KUMAR SARMA³

^{1,2}Dept. of Electronics and Communication Engineering, Gauhati University, Guwahati-14, Assam, India

³Dept. of Electronics and Communication Technology, Gauhati University, Guwahati-14, Assam, India

E-mail – dekasurajit123@gmail.com, manashpelsc@gmail.com, kandarpaks@gmail.com

Abstract- In this paper, we describe the design and implementation of a rake receiver for use with ultra wide band (UWB) systems. The rake receiver uses spread spectrum modulation (SSM) aided by kasami sequence generator. The combination is found to be effective in dealing with multipath fading and signal to noise ratio. The design is initially simulated using MATLAB 7.10 and is implemented using a HDL coder. The design is also implemented in a FPGA kit and is found to be effective in interference mitigation as part of a CDMA framework.

Index Terms- CDMA, HDL coder, VHDL, MATLAB, Simulink, Fading, FPGA, Channel Estimation, MRC.

I. INTRODUCTION

As demand for wireless communications continues to grow, third-generation cellular communications systems are being standardized to provide flexible voice and data services. A rake receiver, which resolves multipath signals corrupted by a fading channel, is the most complex and power consuming block of a modem chip. Therefore, it is essential to design a rake receiver be efficient in power. A rake receiver has multiple fingers to resolve multipath signals corrupted by a fading channel. Each finger has a channel estimator and a channel compensator to mitigate the phase rotation due to the fading channel. A rake receiver also includes a time tracker for fine-tuning of the timing and a combiner to combine outputs of the fingers. In the past decades, mobile communication systems have proliferated explosively and offer a wide variety of communication services. The 3G systems employ high-speed versions of CDMA called Wideband CDMA (WCDMA) or CDMA 2000. CDMA2000 is the other 3G standard that competes with WCDMA. It is an upgrade for Interim Standard-95 (IS-95). CDMA2000 uses a synchronous network relying on the Global Positioning System (GPS). CDMA2000 is the other 3G standard that competes with WCDMA. It is an upgrade for Interim Standard-95 (IS-95) [1].

In this paper, we describe the design and implementation of a rake receiver for use with (UWB) systems. The rake receiver uses spread spectrum modulation (SSM) aided by kasami sequence generator. The combination is found to be effective in dealing with multipath fading and signal to noise ratio. The design is initially simulated using MATLAB 7.5 and is implemented using a HDL coder. The design is also implemented in a FPGA kit and is found to be effective in interference mitigation as part of a CDMA framework. We evaluate the system performance in terms of bit error rate

(BER). The design is implemented at the register transfer level (RTL) in VHDL and synthesized to achieve gate level realization [2]. The rest of the paper is organized below. In section II we briefly describe the different theoretical aspects related to the work. The experimental details is described in section III. Results of present work are included in section IV. The work is connected by section V. Different technology gives different data rates. The comparison among them are given below-

Table I: Comparisons of Data Rates among different Technology

Serial Number	Technology	Data Rates
FIRST	IS-95B	115.2 kbps
SECOND	GPRS	171.0 kbps
THIRD	EDGE	473.0 kbps
FOURTH	WCDMA	2072.0 kbps

II. THEORETICAL DESCRIPTION

Here we cover the basic theoretical motions related to the work. The generic SSM transmitter is as in Figure 1.

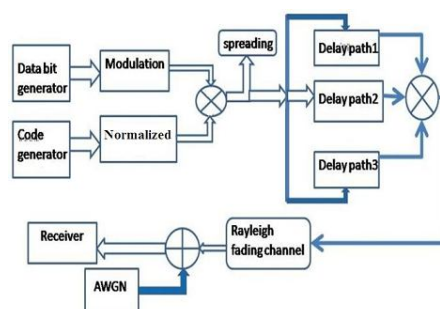

Figure 1: Block diagram of generic SSM transmitter.

A. Code sequence generator: - There are different types of code generation techniques. Mainly the following types of code sequence are used in Rake receiver design. These are -

- (a) Gold code sequence.
- (b) Pseudo noise Sequence and
- (c) Kasami sequence.

Here we briefly describe the Kasami sequence. There are two sets of Kasami sequence. These are – small set and the large set. The large Set contains all the sequences in the small set. Only the small set is optimal in the sense of matching Welch's lower bound for correlation functions. Kasami sequences have period $N = 2^n - 1$, where n is a nonnegative, even integer. Let u be a binary sequence of length N , and let w be the sequence obtained by decimating u by $2^{n/2} + 1$. The small set of Kasami sequences is defined by the following formulas, in which T denotes the left shift operator, m is the shift parameter for w , and \oplus denotes addition modulo 2. The small set contains $2^{n/2}$ sequences. A small set Kasami sequence is expressed as

$$k_{x(u,n,m)} = \left\{ \begin{array}{ll} u, & m = -1 \\ u \oplus T^m w, & m = 0, \dots, 2^{\frac{n}{2}} - 2 \end{array} \right\} \quad (1)$$

For $\text{mod}(n, 4) = 2$ the large set of Kasami sequences is defined as in equations 2. Let v be the sequence formed by decimating the sequence u by $2^{n/2+1} + 1$. The large set is defined by the following table, in which k and m are the shift parameters for the sequences v and w , respectively. Large Set of Kasami Sequences for $\text{mod}(n, 4) = 2$ is expressed as

$$K_L(u, n, k, m) = \left\{ \begin{array}{ll} u; & k = -2; m = -1 \\ v; & k = -1; m = -1 \\ u \oplus T^k v; & k = 0, \dots, 2^n - 2; m = -1 \\ u \oplus T^m w; & k = -2; m = 0, \dots, 2^{\frac{n}{2}} - 2 \\ v \oplus T^m w; & k = -1; m = 0, \dots, 2^{\frac{n}{2}} - 2 \\ u \oplus T^k v \oplus T^m w; & k = 0, \dots, 2^n - 2; m = 0, \dots, 2^{n/2} - 2 \end{array} \right. \quad (2)$$

Where, n is the degree of the Generator polynomial, we can specify Sequence index as an integer vector $[k \ m]$. In this case, the output sequence is from the large set. The range for k is $[-2 \dots 2n - 2]$, and the range for m is $[-1, \dots 2n/2 - 2]$.

B. Spread spectrum modulation: Spread-spectrum communication is one in which the transmitted signal is spread over a wide frequency band, typically much wider than the minimum bandwidth required to transmit the data. The spreading uses a waveform that appears random to anyone except the intended receiver of the transmitted signal. Spreading consists of multiplying the input data by a pseudo-random or pseudo-noise (pn) sequence, the bit rate of which is

much higher than the data bit rate. This increases the data rate while adding redundancy to the system. The ratio of the sequence bit rate to the data rate is known as the spreading factor.

C. QPSK modulation:- For CDMA mostly QPSK modulation is used. Phase Shift Keying (QPSK) is the digital modulation technique. Quadrature Phase Shift Keying (QPSK) is a form of Phase Shift Keying in which two bits are modulated at once, selecting one of four possible carrier phase shifts (0, $\Pi/2$, Π , and $3\Pi/2$) [3].

D. Rayleigh fading channel:- Typically, the fading process is characterized by a Rayleigh distribution for a non line-of-sight path and a Rician distribution for a line-of-sight path. If the fading observed in wireless channels do not have a line of sight (LOS) component it is called a Rayleigh fading [3].

E. Maximum-likelihood sequence estimation equalizer:- Time-dispersive channels can cause inter-symbol interference (ISI), a form of distortion that causes symbols to overlap and become indistinguishable by the receiver. For example, in a multipath scattering environment, the receiver sees delayed versions of a symbol transmission, which can interfere with other symbol transmissions. An equalizer attempts to mitigate ISI and improve receiver performance. MLSE Equalizer block use the Viterbi algorithm to equalize a linearly modulated signal through a dispersive channel [4].

F. AWGN noise :- Additive white Gaussian noise (AWGN) is a channel model in which the only impairment to communication is a linear addition of wideband or white noise with a constant spectral density (expressed as watts per hertz of bandwidth) and a Gaussian distribution of amplitude. Wideband Gaussian noise comes from many natural sources, such as the thermal vibrations of atoms in conductors (referred to as thermal noise or Johnson-Nyquist noise), shot noise, black body radiation from the earth and other warm objects, and from celestial sources such as the Sun. The AWGN channel is a good model for many satellite and deep space communication links [5].

G. Maximal Ratio Combining (Combining weight coefficient and finger delay):- MRC is the optimist form of diversity combining cause of Maximum ratio combining all the integration result of code sequence by this we achieve better bit error ratio (BER) and maximum signal to noise ratio (SNR).

III. EXPERIMENTAL DETAILS

The system model of the proposed approach is shown in Figure 2. It is a rake receiver design to work as part of a CDMA set up for application in fading channels.

Since, spreading is an important task in rake receiver design. So, we have compared all the spreading combination of different code generator and data bit generators. There are different types of data bit generation techniques. A few of the considered types are- Bernoulli-binary generator and random integer generator.

Also, there are different types of code generation techniques. A few of the considered types are – OVFSF code (for orthogonal spreading), Hadamard code (for orthogonal spreading), PN sequence (pseudo random spreading) Gold code (pseudo random spreading)and Kasami sequence (pseudo random spreading). The modulation techniques which is used are QPSK (used for complex signal spreading). BPSK (used for real signal spreading). Our spreading model consists of two segments with and without rake. We describe the working separately for each of the segment as follows-

A. Without Rake:-The real spreading comparison model consist of the following way-

- Step1- Orthogonal real spreading with BPSK, Random integer data bit generator, Hadamard code (for two users).
- Step2- Orthogonal real spreading with BPSK, Bernoulli- binary data bit generator, Hadamard code (for two users).
- Step3- Orthogonal real spreading with BPSK, Random integer, Orthogonal variable spreading factor (for two users).
- Step4- Orthogonal real spreading with BPSK, Bernoulli-binary, Orthogonal variable spreading factor (for two users).

Table II: Comparison value of different coding schemes without rake (for real spreading)

Code generator	Data-bit generator	Sing le user BER	Dou ble user BER	Single user symbol compared	Doubl e user symbol compared
Hadamard code	Rand om integer	.03885	.03897	932	886
Hadamard code	Berno ulli binary	.03885	.03512	932	842
OVFSF code	Rand om integer	.03672	.03693	881	886
OVFSF code	Berno ulli	.03672	.03512	881	842

The complex spreading comparison model consist of the following steps-

- Step1- Orthogonal complex spreading with QPSK, Bernoulli binary data bit generator, orthogonal variable spreading factor (OVFSF) (for single & two users).
- Step2- Orthogonal complex spreading with QPSK, Bernoulli binary data bit generator, Hadamard code (for single & two users).
- Step3- Orthogonal complex spreading with QPSK, Random integer data bit generator, Hadamard code (for single & two users).
- Step4- Orthogonal complex spreading with QPSK, Random integer data bit generator, OVFSF (for single & two users).

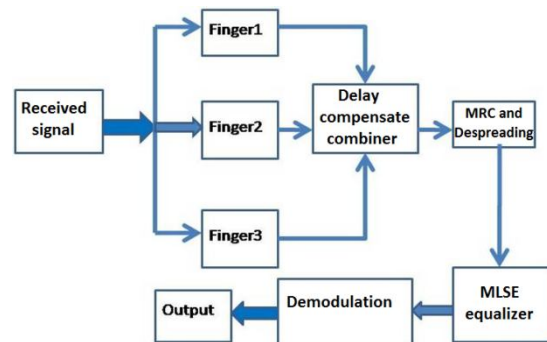

Figure 2: Proposed model of rake receiver.

B) With rake: - The complex spreading comparison model consists of the following steps. For multiple path propagation the combination of random integer with kasami sequence gives the better output. The different possible combinations are mention below-

- i) PN sequence generator with Random integer generator.
- ii) Gold code generator with Random integer generator.
- iii) Kasami sequence with Random integer generator.

IV. RESULTS OF PRESENT WORK

Here we provide the experimental results in the same sequence as it is described in the system model.

A comparative depiction of the results is shown in Table I. First, we carryout a comparative study of real spreading model for single user and double user in combination of the codes mention in the Table I. For single user case, the combination of random integer with OVFSF codes gives less BER. This gives BER value nearly equal to that obtained using the Bernoulli code generator.

Table III: Comparison value of different coding schemes without rake (for complex spreading)

Code generator	Data-bit genera	Sing le user	Dou ble user	Single user symbol	Doubl e user symbol
----------------	-----------------	--------------	--------------	--------------------	---------------------

	tor	BE R	BER	l compa red	l compa red
Hadamard code	Random integer	.07257	.07354	1741	1788
Hadamard code	Bernoulli-binary	.07328	.07361	1758	1786
OVSF code	Random integer	.07361	.07436	1766	1784
OVSF code	Bernoulli-binary	.07361	.07436	1766	1784

Table IV: Comparison value of different coding schemes with rake (for complex spreading)

Code generator	Data-bit generator	Rake combine output BER with MLSE	Rake combine output BER with LMS
PN sequence	Random integer	.7529	.7593
Gold code	Random integer	.7462	.7492
Kasami sequence	Random integer	.5894	.7366

From the experimental results of Table I. and Table II, we see that for multiple users complex spreading case random integer generator is better than other cases. So, in Table III we have used random integer as data bit generator. From the comparison of all the three combinations which we have used in our proposed model, Kasami sequence generator gives least BER value. So, we have used Kasami sequence as our code generator. With Kasami sequence, we can now see almost perfect user separation over multiple paths with the gains of combining. This can be attributed to the better correlation properties of Kasami sequences, which provide a balance between the ideal cross-correlation properties of orthogonal codes and the ideal auto-correlation properties of PN sequences.

Before MRC block we have used delay compensate block to reduce the individual multipath delay and also estimate the channels. We have combined this signal with maximal ratio combiner to get less bit error rate and maximum SNR. Further through MLSE

equalizer it is possible to get better power efficiency and less faded output.

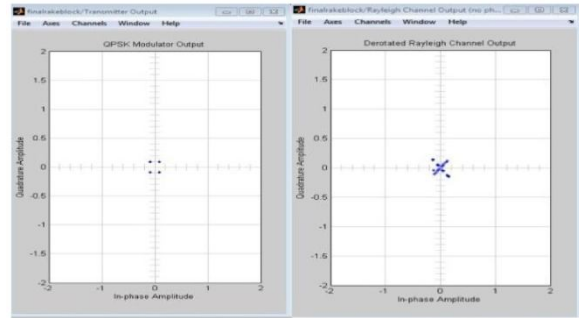

Figure 3: QPSK modulated & Rayleigh fading channel output

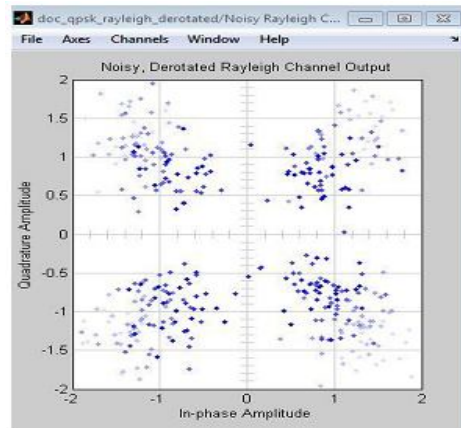

Figure 4: Scatter plot output after AWGN noise.

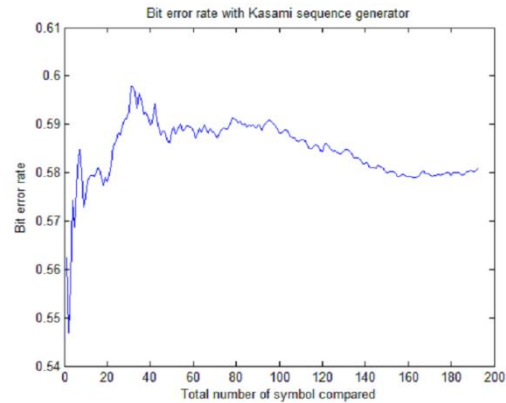

Figure 5: Rake output with Kasami sequence and random integer generator.

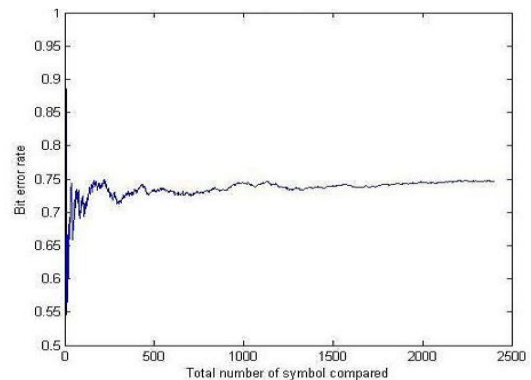

Figure 6: Rake output with Gold code sequence and random integer generator.

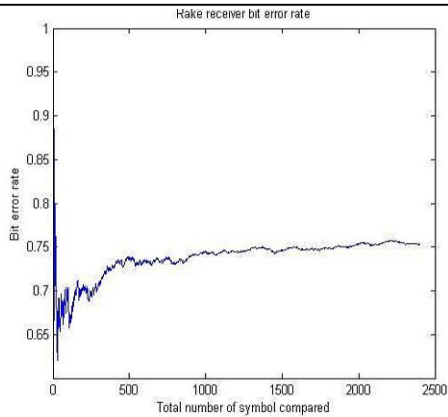

Figure 7: Rake output with PN- sequence and Random integer generator

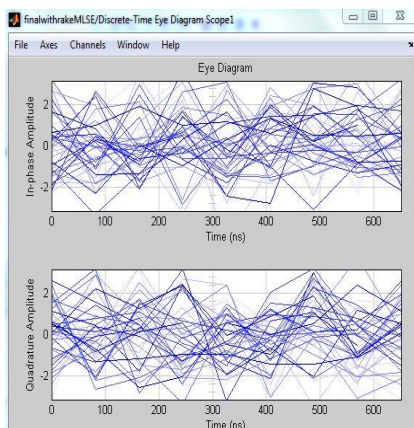

Figure 8: Rake receiver output with eye diagram before equalization.

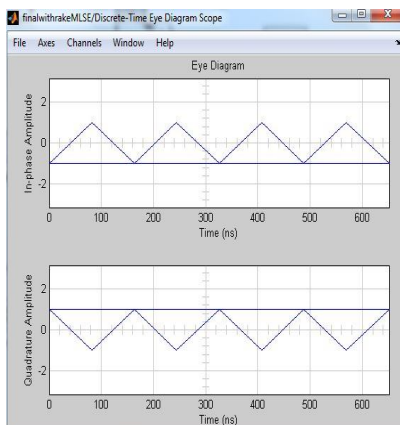

Figure 9: Rake receiver output with eye diagram after MLSE equalization.

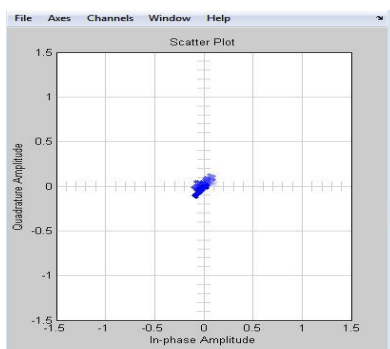

Figure 10: Scatter plot output after MLSE equalization.

The calculated bit error rate at the output of our proposed model with Kasami sequence generator is found to be 0.5894 with respect to 231 symbols (samples) as shown in Figure 5 and Table IV. In our model we have considered a Rayleigh fading channel and the constellation of faded transmitted signal is shown in Figure 3. The addition of AWGN noise further degrades the signal whose effect is shown in Figure 4. Also the rake receiver output before and after equalization is presented in Figure 8 and Figure 9, which shows both in-phase and quadrature components separately. Both the in-phase and quadrature components are changing continuously during transmission of the signal.

V. CONCLUSION & FUTURE DIRECTION

Here, we proposed the design and implementation of a rake receiver model based on CDMA principles for UWB applications. The performance analysis of a rake receiver employing a MLSE equalizer is presented here. The system is validated with different code sequences like PN sequence, Gold sequence and Kasami sequence with the use of a QPSK modulation. The analysis for all the sequences finally depicts that the double user orthogonal spreading with random integer and Hadamard code gives better output. Also Kasami sequence with random integer generator is observed to result in low BER as compared to PN and Gold sequences.

The calculated bit error rate is .5894 with respect to compared symbols as shown in Figure 5. The Rayleigh faded signal, AWGN degraded version of the system and scatter plot output after MLSE equalization has been presented in Figure 3, Figure 4 and Figure 10 respectively. Incorporating an MLSE equalizer the results for both I & Q channels were observed and verified which has proved to be an efficient technique to mitigate fading. The use of MRC block further gives maximum SNR. Finally it can be concluded that better power efficiency is possible with an equalizer which is evident from the eye diagram in Figure 10 and scatter plot of Figure 6. Further through MRC (maximal ratio combining) and IQ de-mapping it is possible to get better power efficiency and less faded output. This leads us to think of implementing the design in a power aware framework.

REFERENCES

- [1] J. Kurzweil, "An Introduction to Digital Communications," New York, John Wiley and Sons, 2000.
- [2] J. Bhaskar, "A Vhdl Primer" PEARSON Education, Third Edition, 2008.
- [3] M. Z. Win and R. A. Scholtz, "Ultra-Wide Bandwidth Time-Hopping Spread-Spectrum Impulse Radio for Wireless Multiple-Access communications,"

- Transactions on Communications, vol. 48, April 2000, pp. 679-689.
- [4] M. Z. Win and R. A. Scholtz, "Impulse radio: How it Works," IEEE Commun. Lett. vol. 2, Jan. 1998, pp. 10-12.
- [5] J. G. Proakis, Digital Communications, Fourth Ed., New York, McGraw-Hill, 2001.
- [6] S. Haykin, "Adaptive Filter Theory," Prentice Hall, 1996.
- [7] Ratnam V. R. Kumar, A.Kumar, "Development of a CDMA System with Rake Receiver for the third Generation Wireless Communication System"; 2002 IEEE (ICPWC'2002) pg 309-313.
- [8] J. D. Choi and W. E. Stark, "Performance of Ultra Wideband Communications with Suboptimal Receivers in Multipath Channels," Journal on Selected Areas in Communications, vol. 20, dec 2002, pp. 1754-1766.
- [9] A. Aziz, "Channel Estimation for a WCDMA Rake Receiver," Application Note, AN2253, Rev. 2, Free scale Semiconductor, November 2004.
- [10] T.Heikkila, "RAKE RECEIVER"S72.333 Postgraduate Course in radio Communication, autumn 2004.
- [11] F. Adachi et. al., "Broadband CDMA Techniques," IEEE Wireless communications, vol. 12, no. 2, pp. 8-18, Apr. 2005.
- [12] M. Ali Akbar, H. B. Tila, M. Z. Khalid and M. A. Ajaz —Bit Error Rate Improvement Using ESPRIT based Beam forming and RAKE Receiver, 978-14244- 4873-9/09/©2009 IEEE.
- [13] S. Haykin, Adaptive Filter Theory, Third Ed., Upper Saddle River, NJ, Prentice-Hall, 1996.
- [14] R. Steele, Ed., Mobile Radio Communications, Chichester, England, John Wiley and Sons, 1996.

