

April 2014

RENEWABLE ENERGY BASED AGRICULTURAL ROBOT

R. KRISHNA

Thiagarajar College of Engineering, Madurai, India, krinampad@gmail.com

J.ENOCH RICHBERT

Thiagarajar College of Engineering, Madurai, India, J.ENOCHRICHBERT@gmail.com

J. JEYAKARAN

Thiagarajar College of Engineering, Madurai, India, J.JEYAKARAN@gmail.com

R. KIRUBHAKARAN

Thiagarajar College of Engineering, R.KIRUBHAKARAN@gmail.com

S. DHINAKAR

Thiagarajar College of Engineering, Madurai, India, S.DHINAKAR@gmail.com

Follow this and additional works at: <https://www.interscience.in/ijmie>



Part of the [Manufacturing Commons](#), [Operations Research](#), [Systems Engineering and Industrial Engineering Commons](#), and the [Risk Analysis Commons](#)

Recommended Citation

KRISHNA, R.; RICHBERT, J.ENOCH; JEYAKARAN, J.; KIRUBHAKARAN, R.; and DHINAKAR, S. (2014) "RENEWABLE ENERGY BASED AGRICULTURAL ROBOT," *International Journal of Mechanical and Industrial Engineering*: Vol. 3 : Iss. 4 , Article 1.

Available at: <https://www.interscience.in/ijmie/vol3/iss4/1>

This Article is brought to you for free and open access by Interscience Research Network. It has been accepted for inclusion in International Journal of Mechanical and Industrial Engineering by an authorized editor of Interscience Research Network. For more information, please contact sritampatnaik@gmail.com.

RENEWABLE ENERGY BASED AGRICULTURAL ROBOT

R.KRISHNA¹, J.ENOCH RICHBERT², J.JEYAKARAN³, R.KIRUBHAKARAN⁴ & S.DHINAKAR⁵

Thiagarajar College of Engineering
E-mail: krinampad@gmail.com

Abstract- This paper deals with how to mechanize agricultural process through electronic and embedded components. The aim of the paper is to elaborately explain the processes done by the so called robot.

Keywords- renewable energy, PLC, timer.

I. INTRODUCTION

Agriculture is the backbone of Indian economy. But the state of agriculture is in its decreasing trend. This is due to lack of mechanization. Moreover there is need for a combination of electrical and agricultural scientists working together for the development. This ncreases the per hectare productivity of the agricultural land.

Electricity for this can be obtained from renewable energy resources like that of a solar.thus this robot is cleanenergy based farmer friendly device.

II. AGRICULTURAL PROCESSES

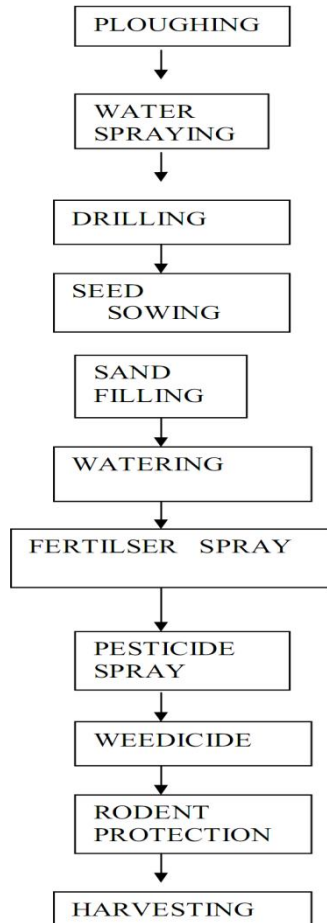

II. DESIGN OF ROBOT

A robot has to be designed to do all these jobs in an efficient as well as marketable manner such that it helps farmers from hectic workforce. For a case study this paper aims at designing a agrobot for vegetable crops.

PLOUGHING:

The robot has a transmitter and receiver circuit with which remote controlling activities can be done. The robot has two notches on either of its lateral surfaces. upon which a multi teeth plough can be attached .the robot can be moved using the remote according to wish of the farmer .hence the entire farmland can be ploughed.

WATER SPRAYING:

The robot consists of a water tank .The outlet of water tank is passed through a tube that deviates into two passages each electronically controlled. One of the passage is attached with a sprayer at its end during this spraying process the passage one is electronically opened and the water is sprayed throughout the field such that robot can easily drill for further processes as said below.

DRILLER

The driller is a long metal rod that consists of some spirals .the top of the driller consists of a gear .this part of the driller is connected to another gear that is connected with a servo motor. Hence when actuated the motor rotates, this causes the drilling action and makes a hole in the soil.

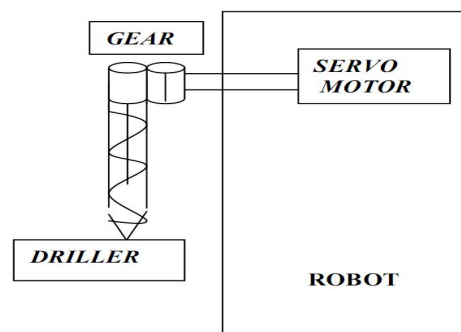

SOWING:

The sower mechanism system is at a distance of say 'x'. This x is loaded to the microcontroller system. After drilling is over, a distance of "x" is moved by the robot and sowing is done.

Sowing mechanism consists of following component.

1. A seed tube [normally L shaped]
2. A nozzle with air pressure source
3. A pivot and a servomotor mechanism.

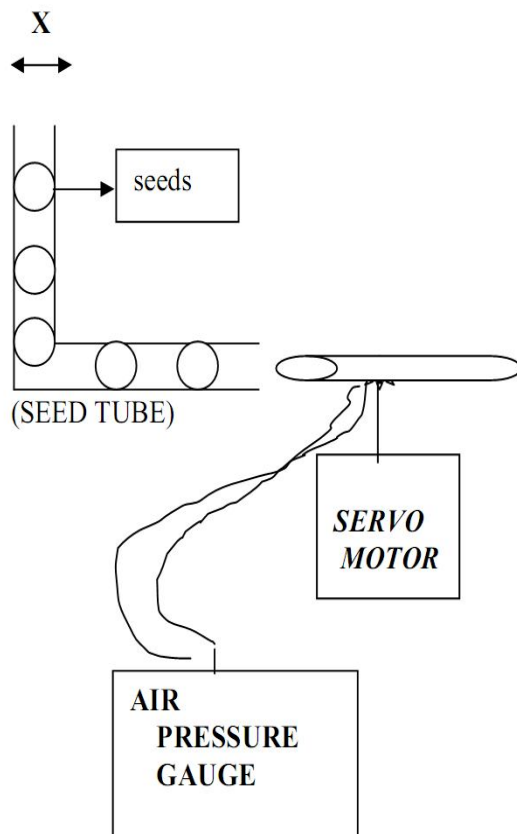
**WORKING:**

1. Seeds are loaded in the tube ("X" > size of seed)
2. A lengthy tube connected is connected with an air pressure gauge ("Y" << seed size), where Y is diameter of nozzle tube.
3. This tube is upon a pivot connected with a servo motor mechanism.
4. Now air pressure is created using the air pressure gauge and hence the seed is absorbed.
5. Now using servo motor the tube is rotated 90 degrees whose values is loaded in micro controller and then moved a distance downwards depending on the height of the base of the robot.
6. Now the pressure is made zero dropping the seed into the hole created in the sand.

FILLING WITH SAND

A brush with round structure is made to rotate in 360 degrees 6 to 7 times so that it can move sand into the hole thus filling it.

WATERING OF PLANTS:

Soils are of many types namely sandy, loamy, clayey in nature. Different soil requires different quantity of water to be added for better growth of plants and to avoid water logging. For eg.) the sandy soil requires daily watering whereas loamy soil requires water once in 2 days and clayey soil requires watering once in 3 days.

Watering can be done in following ways:-

Let the flow rate of water for particular tube depending on design = "R"

Let the quantity of water increase of a vegetable in a particular place = "Q"

Then time = $R \times Q = "T"$ is calculated. This "T" is loaded in the timer of PLC.

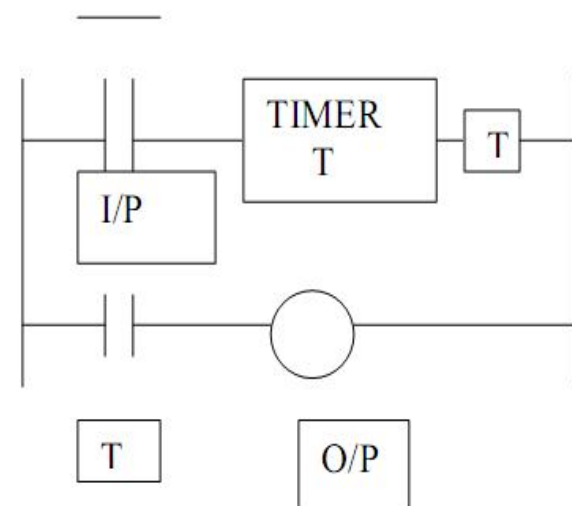

I/P = Input

O/P = Output

Here the output is the water flowing out of the pipe. The water coming out is given to plant through passage 2 as mentioned previously.

FERTILISER APPLICATION:

The fertilizer to be used is mixed with water and is poured in the fertilizer tank. The same logic as that of water pouring is used to give fertilizer to plant.

PESTICIDE APPLICATION:

The amount of pesticide to be applied to plants is also done the same way as that of water irrigation; the pesticide is present in pesticide tank. In addition the pesticide coming out is poured through a sprayer. Since the pesticide has to be sprayed to the whole plant, a small rail is placed vertically upon which the sprayer can move.

SOLAR PANEL:

A solar panel is placed at a height from base cliffs along with a manual tracker system. The solar panel is capable of producing 30 V and output of the panel is used to charge a lead acid battery placed inside the robot. This is also used to run other appliances inside. The tracker can be placed in three positions manually they are 45 degrees towards south, 180 degrees, 45 degrees towards north.

III. FUTURE IMPROVEMENTS:

1. Weed removal by robot
2. Rodent protection
3. Harvesting

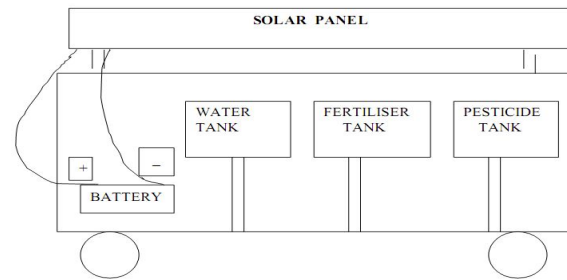
SIDE VIEW OF ROBOT:**IV. CONCLUSION**

Hence this robot has centralized automated system to perform almost all agricultural applications

REFERENCES

1. www.agrobot.com
2. www.wikipedia.com
3. www.google.com

