

October 2013

## OPTIMAL PLACEMENT OF PHASOR MEASUREMENT UNITS FOR POWER SYSTEM OBSERVABILITY

RAJPAL SAINI

*Deen Bandhu Chhotu Ram University of Science And Technology (Murthal), Haryana, India,*  
rajsaini2184@yahoo.in

MANJU MAM

*Department of Power Management, National Power Training Institute(FRD.), Haryana(India),*  
manjumam@yahoo.com

MANISH KR. SAINI

*Deen Bandhu Chhotu Ram University of Science And Technology (Murthal), Haryana, India,*  
itsmemanishkumar@gmail.com

Follow this and additional works at: <https://www.interscience.in/ijpsoem>



Part of the [Power and Energy Commons](#)

---

### Recommended Citation

SAINI, RAJPAL; MAM, MANJU; and SAINI, MANISH KR. (2013) "OPTIMAL PLACEMENT OF PHASOR MEASUREMENT UNITS FOR POWER SYSTEM OBSERVABILITY," *International Journal of Power System Operation and Energy Management*. Vol. 2 : Iss. 4 , Article 8.

Available at: <https://www.interscience.in/ijpsoem/vol2/iss4/8>

This Article is brought to you for free and open access by Interscience Research Network. It has been accepted for inclusion in International Journal of Power System Operation and Energy Management by an authorized editor of Interscience Research Network. For more information, please contact [sritampatnaik@gmail.com](mailto:sritampatnaik@gmail.com).

# OPTIMAL PLACEMENT OF PHASOR MEASUREMENT UNITS FOR POWER SYSTEM OBSERVABILITY

RAJPAL SAINI<sup>1</sup>, MANJU MAM<sup>2</sup> & MANISH KR. SAINI<sup>3</sup>

<sup>1&3</sup>Dept. of Electrical Engineering, Deen Bandhu Chhotu Ram University of Science And Technology (Murthal), Haryana, India

<sup>2</sup>Dept. of Power Management, National Power Training Institute(FRD.), Haryana, India  
E-mail : rajsaini2184@yahoo.in<sup>1</sup>, manjumam @yahoo.com<sup>2</sup>, itsmemanishkumar@gmail.com<sup>3</sup>

---

**Abstract** - This paper present a method to find minimum number of phasor measurement units (PMUs) for complete observability of power system network for normal operating conditions. A linear algorithm is used to determine the minimum number of PMUs needed to make the system observable. For state estimation and fault diagnosis in power system synchronized snapshot of whole system must be necessary. The proposed method is used to benchmark the optimal PMUs placement solution for the IEEE 14-bus, IEEE 18- bus, IEEE 30-bus and IEEE 57-bus test systems.

**Keywords** - *Phasor Measurement Units (PMUs), Linear Algorithm (LA), Optimal Placement of PMUs (OPP), Global Positioning System (GPS), Power System Observability.*

---

## I. INTRODUCTION

Phasor Measurement Units (PMUs) become more and more imported and attractive to power engineers because they can provide synchronized measurements of real-time phasors of voltage and currents [1]. As the state estimator play an important role in the security of power system to enhance state estimation in a problem needed to be solved. Several algorithms have been published in the literature. Until recently, it was not possible to measure phase angle of the bus voltage in real time due to the technical difficulties in synchronizing measurements from distant locations, But introducing the PMUs in power system, possible to measure the real-time phasors of voltages and currents at widely dispersed locations with respect to a global positioning system (GPS) clock [2].

The methodology is needed to determine the optimal location of PMUs in a power system. In addition to its ability to measure voltage and current phasors, a state-of-the-art PMU may include other features such as protective actions. The objective of the present work is to find the minimum number of PMUs to make the system topologically observable, as well as the optimal locations of these PMUs. In recent year, there has been a significant research activity on the problem of finding the minimum number of PMUs and their optimal locations. In [3], a bisecting search method is implemented to find the minimum number of PMUs to make the system observable. The simulated annealing method is used to randomly chose the placement sets to the test for observability at each step of the bisecting search. In [1], the authors use a simulated annealing technique in their graph-theoretic procedure to find the optimal PMU locations.

In [5] and [6] the authors use integer programming to determine the minimum number of PMUs. The method, however may suffer from the problem of being

trapped in local minima. Multiple objectives, such as minimizing the measurement redundancy, can not be handled by integer programming. In [7]-[8], the OPP optimization problem is solved using PSAT, a MATLAB based toolbox, and depth first search (DeFS) method is compared with other methods. Another depth first search (DeFS) method is proposed in [9]. The DeFS algorithm is computationally faster, but the solution is not optimum, because the optimization criterion is stiff. A modified depth first approach is the minimum spanning tree (MST) method [9]. The MST algorithm improves the DeFS approach, which also has fast computing characteristics, and improves DeFS's complex and weak convergence. A novel topological method based on the augment incidence matrix and Tabu Search (TS) algorithm, is proposed in [10]. The solution of the combinatorial OPP problem requires less computation and is highly robust. The method is faster and more convenient than conventional observability analysis methods using complicated matrix analysis, because it manipulates integer numbers. A TS method on meter placement to maximize topological observability is presented in [10]. The GA method suggested in [11] solves the OPP problem using different PMU placement criteria, such as the absence of critical measurements and critical sets from the system, maximum quantity of measurements received as compared to the initial one, maximum accuracy of estimates, minimum cost of PMU placement, and transformation of the network graph into tree. The immune algorithm (IA) is a search strategy based on genetic algorithm principles and inspired by protection mechanisms of living organisms against bacteria and viruses. In reference [12], the application of the immune genetic algorithm (IGA) method to the OPP problem is presented. Utilization of the local and prior knowledge associated with the considered problem is the main idea behind IGA. The

prior knowledge of the OPP problem was inferred based on the topological observability analysis and was abstracted as some vaccines. The injection of these vaccines into the individuals of generations, revealed a remarkable increase in the convergence process. A BPSO algorithm, with the objective of minimum PMU installation costs, is introduced in [13]. A hybrid algorithm based on BPSO and immune mechanism is introduced in [14]. It provides a speedy and general analyzing method of power network topology observation based on the properties of PMU and topological structure information of the power network. The classical ant colony optimization (ACO) algorithm is a probabilistic technique for solving computational problems which can be reduced to finding good paths through graphs. A generalized ACO algorithm is proposed in [15]. The present paper proposes the Linear Algorithm method to minimize the PMUs.

**II. PHASOR MEASUREMENT UNIT(PMU) TECHNOLOGY**

A phasor measurement unit is a device that provides as a minimum , synchro phasor and frequency measurements for one or more three phase AC voltage and/or current waveforms[16].These measure are marked with a GPS time stamp in time intervals down to 20 ms [1].This same time sampling of voltage and current waveforms using a common synchronizing signal from the global positioning setelite ensure synchronicity among PMUs.This synchronicity makes the PMU one of the most important devices for power system control and monitoring.

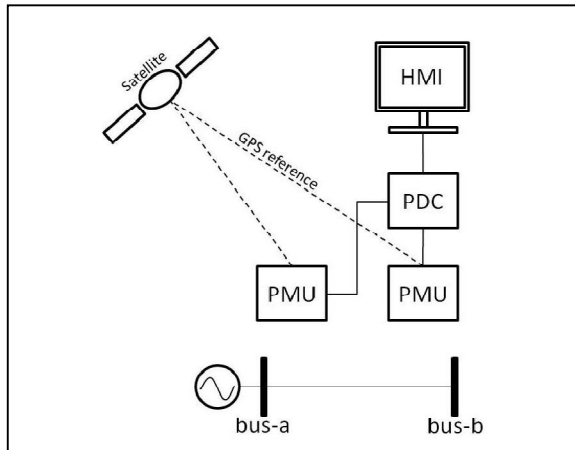

**Fig.1 : PMU Layout with GPS time stamped Signal**

Fig. 1 shows PMUs geographically dispersed to form a wide area monitoring system(WAMS) in which the PMUs deliver GPS time-tagged measurements to a Phasor Data Concentrator (PDC).The PDC sorts the incoming phasor measurements before signal processing converts PMU data into actionable information that can be presented to an operator in the form of a Human Machine Interface(HMI).This HMI provides a operator with critical information about the state of power system.

**III. MATERIALS AND METHODS**

Observability analysis is a fundamental component of real time state estimation .There are two major algorithms for power network observability analysis: topology based algorithms and numerical methods .Topology methods are developed from graph theories, compared to numerical methods that are mainly based on numerical factorization of measurement Jacobi matrices. Numerical methods are less suitable for large system because they are involved with large dimension matrices that increase the computational complexity [1].If we model buses in a power system by vertices and model the transmission and distribution line connecting buses by edge, this problem is converted to be adomination problem and requires the extension of the topological observation thoery.The observation rules [17] can be described as following:-

Rule 1: A bus with PMU installation is observable, and its adjacent buses are all observable because their voltages can be calculated by Ohm’s law with the help of the PMU measurement.

Rule 2: If a bus is adjacent to an observable zero-injection bus to which all other adjacent buses are observable, then the bus is observable because its voltage can be calculated by KCL and Ohm’s law.

Rule3: if all buses adjacent to a zero-injection bus is observable because its voltage can be calculated by KCL and Ohm’s law.

To get the fast solution, a good initial guess of PMUs placement, this algorithm was tested for a list of distribution system and proven very good efficient. In 2002, Haynes et al [4], mathematically proved that, for a tree having k vertices of degree at least 3, the “power dominating number”

$$\gamma p(T) \geq (k+2)/3 \quad (1) \text{ and}$$

$$\gamma p(T) \leq n/3 \quad (2)$$

Where n is the total no. of vertices.

Equation (1) and (2) give the upper and lower bounds for the power dominating number.Although a power system does not have to a tree topology, these theorems corresponded to the computation result from [3] very well. Haynes at al in this paper also gave an algorithm to find out the dominating set S and a partition of the whole set G into S so that each subset induces a “spider”. This algorithm was strictly proven in this paper .In 2009,Mohammadi-Ivatloo summarized most available topological based formulated algorithms ,including genetic algorithm(2009) ,Tabu search (2006), Integer linear programming (2008).However complexity of each algorithm is still left to be discussed . In engineering practice, we are most interested in the dominating set, i.e., where to mount the PMUs.The partition is not the primary concern. Taking advantage of the upper and lower bounds [4], a linear algorithm is proposed in this study; this algorithm is proven especially effective for small system.

**IV. THE LINEAR ALGORITHM**

**Creating a Node –Incidence Matrix for Power System:**

By the topological information of a power system the interconnection of the various buses can be grouped in an array called node-incidence matrix.

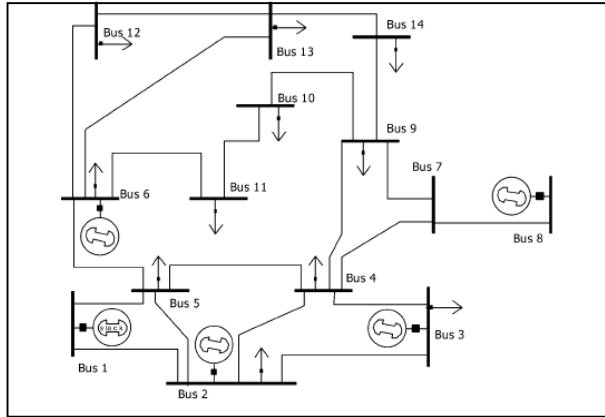

**Fig.1 : IEEE-14 bus system**

To produce the node incidence matrix the rule is simple: If node *i* is connected to node *j*, then  $A_{ij} = 1$ , where  $i \neq j$  and  $A_{ii} = 0$ . Normally *A* is a large sparse matrix. For example, for the IEEE 14-bus system,

$$A = \begin{bmatrix} 0 & 1 & 0 & 0 & 1 & 0 & 0 & 0 & 0 & 0 & 0 & 0 & 0 & 0 \\ 1 & 0 & 1 & 1 & 1 & 0 & 0 & 0 & 0 & 0 & 0 & 0 & 0 & 0 \\ 0 & 1 & 0 & 1 & 0 & 0 & 0 & 0 & 0 & 0 & 0 & 0 & 0 & 0 \\ 0 & 1 & 1 & 0 & 1 & 0 & 1 & 0 & 1 & 0 & 0 & 0 & 0 & 0 \\ 1 & 1 & 0 & 1 & 0 & 1 & 0 & 0 & 0 & 0 & 0 & 0 & 0 & 0 \\ 0 & 0 & 0 & 1 & 0 & 0 & 0 & 0 & 0 & 1 & 1 & 1 & 0 & 0 \\ 0 & 0 & 0 & 1 & 0 & 0 & 0 & 1 & 1 & 0 & 0 & 0 & 0 & 0 \\ 0 & 0 & 0 & 0 & 0 & 0 & 1 & 0 & 0 & 0 & 0 & 0 & 0 & 0 \\ 0 & 0 & 0 & 1 & 0 & 0 & 1 & 0 & 0 & 1 & 0 & 0 & 0 & 1 \\ 0 & 0 & 0 & 0 & 0 & 0 & 0 & 1 & 0 & 1 & 0 & 0 & 0 & 0 \\ 0 & 0 & 0 & 0 & 0 & 1 & 0 & 0 & 0 & 1 & 0 & 0 & 0 & 0 \\ 0 & 0 & 0 & 0 & 0 & 1 & 0 & 0 & 0 & 0 & 0 & 0 & 1 & 0 \\ 0 & 0 & 0 & 0 & 0 & 0 & 0 & 1 & 0 & 0 & 0 & 1 & 0 & 1 \end{bmatrix}$$

It is easy to find out that there are 8 nodes with degree 3 or more. Here  $K=8$  and  $n=14$ . so, the number of PMUs needed that is, the only possible values for *S* between 3 and 4 using equation (1) and (2). Now we want to find out the minimum number of PMUs, and the dominating set *S*. The basic idea of this algorithm is to test all possible node combinations by the observation rules, until one combination is found to be able to “observe” all the system. We call a test for a combination as a measurement. For the IEEE 14-bus system, the maximum number of measurements is number of combinations produce by selecting numbers of a group in between 3-4, who will converge, will give the required number of PMUs in the system. That is 70 for IEEE 14-bus system. We need to keep in mind that, in the implementation of the algorithm, we may not have to run all the 70 measurements to find out the *S*-set. The number of measurement before we get an *S*-set

(which is usually not unique) can be any number between 1 and 70.

**V. ALGORITHM FOR FINDING THE MINIMUM NUMBER OF PMU’S**

**Begin**

1. Read in node-incidence matrix *A* with all buses (nodes) in the system says *G*.
2. Calculate the bounds of *S*.
3. Check the observability of the system by creating loop starting from the lower bound, to the upper bound:
  - a. Generate a node combination, e.g., {2, 4, 5}. These nodes are mounted with PMUs, thus observed. Save them in array *O*.
  - b. Find out all nodes adjacent to these 3 or 4 nodes.
  - c. Save them in array *O*.
4. Find out all nodes that are not in *O*.
  - a. Pick up such a node *j*, use rule 4 to judge if it is observed. If yes, put *j* in *O*, and pick up another node and check.
  - b. if all “not-in-*O*” nodes have been checked, compare *O* to the whole set *G*.
5. If  $O=G$ , output the node combination. That is the *S*-set. Quit. If  $O$  is not equal to *G*, generate another node combination.
6. If solution does not converge then increase the numbers in the group by one toward upper bound.
7. Output how many number of combination has been tried that is the number of measurement.

**END**

**VI. RESULTS AND DISCUSSION**

The linear algorithm is implemented by Matlab (version 7.8.0.347) and is tested for IEEE 14, 18, 39, 57-bus systems. The results are given and compared to other methods. Table 1 give the comparison of computation results by different algorithms. Table 2 give the bus locations where the PMUs will be installed. Due to large computational time and complexity, it not works properly on large bus network like on 57-bus system and above. The best results are found on IEEE 14, 18, 30-bus systems. The proposed method is very fast in providing optimal solution as compared to other search methods. Simulation results for different network show the effectiveness of the proposed method in finding the minimum optimal number of PMU bus locations for complete observability assessment of Power Systems.

Sr. No.	RESULTS		
	Power System (bus no. <i>N</i> )	Method	<i>V</i>
1.	IEEE-14 bus	Proposed Linear Algorithm	3
		Dual Search	3

		Graphic theoretic procedure	5
		Genetic Algorithm	4
2.	IEEE-18 bus	Proposed Linear Algorithm	4
		Genetic Algorithm	4
3.	IEEE-30 bus	Proposed Linear Algorithm	7
		Graphic theoretic procedure	11
		Genetic algorithm	7
4.	IEEE-57 bus	Proposed Linear Algorithm	N/A

**TABLE 1**

Comparison of Result with different Algorithm Where :- N: number of buses , V: minimum number of pmus required

Power System	No. of PMU's	Bus Locations of PMUs
IEEE-14 bus	3	2,6,9
IEEE-18 bus	4	4,6,12,15
IEEE-30 bus	7	2,6,10,12,15,25,17
IEEE-57 bus	N/A	N/A

**TABLE 2**

Bus Locations Of PMUs

**VII.CONCLUSION**

The proposed linear algorithm takes advantage of the upper and lower bounds and the graph theorems that were mathematically proven in [4], which greatly reduced the computation in seeking a dominating set in a power system. Compared to the algorithm in [3] and [18], the proposed algorithm can theoretically guarantee the minimum number of PMUs. Compared to the algorithms in [1] ,it is simpler and easier to be implemented .However, the computation complexity reflected by measurement study indicates that the linear algorithm should be very competitive to other topology based algorithm and other numerical methods and provides complete observability for the distribution system[1].For further study we can try to find such solutions which give lesser capital investment for the PMU placement as the number of communication port ,environmental concerns, technological issues and life cycle also contribute to the cost/unit of a PMU in the system .

**REFERENCES**

[1] R.F. Nuqui and A.G.Phadke ,”Phasor measurement unit placement techniques for complete and incomplete observability,” IEEE Trans. Power Del.,vol. 20 ,no. 4 ,pp. 2381-2388, Oct. 2005.

[2] A.G. Phadke ,”Synchronized phasor measurements in power system,” IEEE Comput . Appl. Power ,vol. 6 ,no. 2 ,pp. 10-15, April 1993.

[3] T.L. Baldwin ,L. Mili ,M.B. Boisen ,and R.Adapa ,”Power system observability with minimal phasor measurement placement ,”IEEE Trans. Power System , vol 8 ,no. 2, pp. 707-715 , May 1993

[4] T. W. Haynes et al, “Domination in Graphs Applied to Electric Power Networks”, SIAM J. Discrete Math., Vol. 15, No. 4, 2002

[5] B. Xu and A. Abur, “Observability analysis and measurement placement for systems with PMUs,” in proc. IEEE Power Eng. Soc. Power Systems Conf. Expo., Oct. 2004, pp. 943–946.

[6] WebpageURL:http://www.naspi.org/resources/pstt/martin\_1\_define\_standard\_pmu\_20080522.pdf, “PMU Basic Specification.

[7] M. Farsadi, H. Golahmadi, and H. Shojaei, "Phasor measurement unit (PMU) allocation in power system with different algorithms", in 2009 Int. Conf. on Electrical and Electronics Engineering, pp. 396-400.

[8] G. Venugopal, R. Veilumuthu, and P. Avila Theresa, "Optimal PMU placement and observability of power system using PSAT," in 2010 Int. Joint Journal Conf. on Engineering and Technology, pp.67-71.

[9] T.-T. Cai and Q. Ai, "Research of PMU optimal placement in power Systems," in 2005 World Scientific and Engineering Academy and Society Int. Conf., pp. 38-43 A. Z.

[10] A. Z. Gamm, I. N. Kolosok, A. M. Glazunova, and E. S. Korkina, "PMU placement criteria for EPS state estimation," in 2008 Int. Conf. on Electric Utility Deregulation and Restructuring and Power Technologies, pp. 645-649.

[11] J. Peng, Y. Sun, and H. F. Wang, "Optimal PMU placement for full Network observability using Tabu search algorithm," International Journal of Electrical Power & Energy Systems, vol. 28, no. 4, pp. 223-231, May 2006.

[12] F. Aminifar, C. Lucas, A. Khodaei, and M. Fotuhi-Firuzabad, "Optimal placement of phasor measurement units using immunity genetic algorithm," IEEE Trans. Power Delivery, vol. 24, no. 3, pp. 1014-1020, Jul. 2009.

[13] M. Hajian, A. M. Ranjbar, T. Amraee, and A. R. Shirani, "Optimal placement of phasor measurement units: particle swarm optimization approach," in 2007 Int. Conf. on Intelligent Systems Applications to Power Systems, pp. 1-6.

[14] C. Peng and X. Xu, "A hybrid algorithm based on BPSO and immune mechanism for PMU optimization placement," in 2008 World Cong. on Intelligent Control and Automation, pp.7036-7040.

[15] W. Bo, L. Discen and X. Li, "An improved ant colony system in optimizing power system PMU placement problem," in 2009 Asia- Pacific Conf. on Power and Energy Engineering, pp. 1-3.

[16] M. Zima, M. Larsson, P. Korba, C. Rehtanz, and G. Andersson, “Design aspects for wide area monitoring and control systems”, Proc. IEEE, vol. 93, no. 5, pp. 980-996, May 2005

[17] Chi Su ,Zhe Chen Institute of Energy Technology “Optimal Placement of Phasor Measurement Units with New Consideration”.

[18] B.Mohammadi-Ivatloo,“Optimal Placement of PMUs for Power System Observability Using Topology Based Formulated Algorithms”,Journal of Applied Sciences ,Vol. 9 , Issue 13,pp 2463 -2468,2009