

July 2013

## ANALYSIS OF CURRENT HARMONICS IN A DECOUPLED SVPWM CONTROLLED DUAL TWO LEVEL INVERTER FED OPEN END WINDING INDUCTION MOTOR DRIVE

K.SRI GOWRI

RGMCET, Nandyal, gowrivasu.3@gmail.com

M. ABDUL HAKEEM

RGMCET, Nandyal, hakeem\_srk@yahoo.com

S. VENKATA MAHESH

RGMCET, Nandyal, venkatamahesh68@gmail.com

Follow this and additional works at: <https://www.interscience.in/ijeee>



Part of the [Power and Energy Commons](#)

---

### Recommended Citation

GOWRI, K.SRI; HAKEEM, M. ABDUL; and MAHESH, S. VENKATA (2013) "ANALYSIS OF CURRENT HARMONICS IN A DECOUPLED SVPWM CONTROLLED DUAL TWO LEVEL INVERTER FED OPEN END WINDING INDUCTION MOTOR DRIVE," *International Journal of Electronics and Electrical Engineering*: Vol. 2 : Iss. 1 , Article 11.

Available at: <https://www.interscience.in/ijeee/vol2/iss1/11>

This Article is brought to you for free and open access by Interscience Research Network. It has been accepted for inclusion in International Journal of Electronics and Electrical Engineering by an authorized editor of Interscience Research Network. For more information, please contact [sritampatnaik@gmail.com](mailto:sritampatnaik@gmail.com).

# ANALYSIS OF CURRENT HARMONICS IN A DECOUPLED SVPWM CONTROLLED DUAL TWO LEVEL INVERTER FED OPEN END WINDING INDUCTION MOTOR DRIVE

<sup>1</sup>K.SRI GOWRI, <sup>2</sup>M. ABDUL HAKEEM & <sup>3</sup>S.VENKATA MAHESH

RGM CET, Nandyal

E-mail : gowrivasu.3@gmail.com, hakeem\_srk@yahoo.com & venkatamahesh68@gmail.com

**Abstract** - Pulse width modulation has been one of the most intensively investigated areas of power electronics for many years now, and the number of combinations seems to be endless. However, according to a hierarchical consensus, Space Vector Modulation techniques are ranked higher in order of merit, based on harmonic performance. In this paper, Space Vector PWM Switching scheme is employed for a dual two level inverter feeding an Induction motor from both ends (open end winding). The decoupled SVPWM is employed for the dual-inverter scheme in order to realize the reference voltage vector. The Gating pulses are correspondingly generated for the dual inverters in order to realize the reference voltage, and the respective voltages are fed to 1kW open end windings of an induction motor drive. The harmonic content of the three phase currents in the motor are analyzed with an appropriate variation in its modulation index. Thus the performance in terms of harmonic analysis is carried out using Matlab/SIMULINK for an open end winding induction motor drive.

**Keywords**- Dual-inverter, Decoupled SVPWM, Open-end winding induction motor

## I. INTRODUCTION

Various PWM schemes are presented for the two-level inverters and their effects on the load are also continuously investigated. Thrive to get improved performance is on the anvil employing suitable PWM technique/s or using multi-level inverters. Multi-level inverters are finding increasing research opportunities and it is clearly evident in the past few years. This is due to the reduced total harmonic distortion (THD) in the output voltage and genesis of higher voltage with use of series connections of lower voltage rating switching devices. Towards this end, a dual-inverter topology employing open-end winding induction motor drive is introduced that is capable of generating multi-level voltage output. Many PWM schemes are reported in the literature on the dual inverter topology that aims at improving the output voltage THD performance, common mode voltage minimization and elimination. The decoupled SVPWM strategy in the present case is used as its name suggests where the SVPWM scheme is applied on both the inverters feeding the open end windings. The gating pulses for the dual inverters are separately generated and inverter output voltages are provided to the three phases of the motor. The harmonic content in the motor phase current is analyzed by comparing both the cases when the motor is fed by single inverter and dual inverters. With a change in the modulation index the corresponding change in the harmonic content in both the cases is observed through the simulation results.

## II. DUAL TWO-LEVEL INVERTER SCHEME

The power circuit configuration of the dual two-inverter inverter feeding an open-end winding

induction motor is shown in Fig.1. The open-end winding induction motor is obtained by simply opening the neutral point of the star connected stator windings of the motor, leaving all the six ends of the three-phase stator windings, accessible to be fed from both its ends (Fig.1). The individual two-level inverters are said to attain 8 switching states independent of the other. These switching states are represented as 1-8 and 1'-8' respectively for inverter-1 and 2 respectively and are tabulated in Table-1.

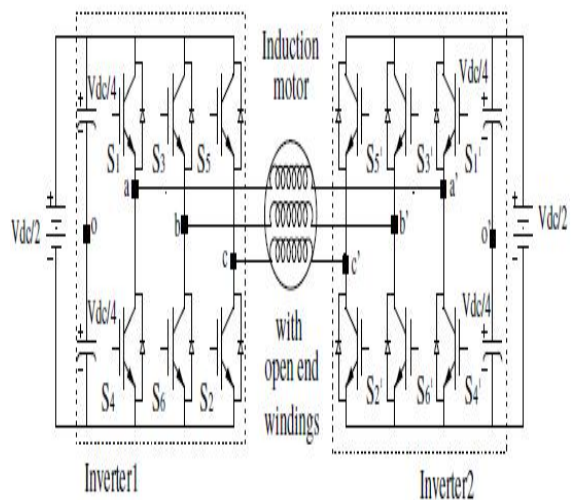

**Fig (1).**Power circuit configuration of dual two-level inverter

In Table-1, a '+' means the top switch in the inverter is on, and a '-' means it is off. This results in a total of 64 switching combinations that are possible with the present circuit topology. Each switching combination in the dual-inverter generates a space vector and the combined space vector diagram covering all the 64 switching combinations are shown in Fig.2. In Fig.2, each side of the sector is

equal to a voltage of  $V_{dc}/2$  only unlike the voltage of  $V_{dc}$  in the conventional two-level inverter.

state of inverter 1	Switches turned on	State of Inverter-2	Switches turned on
1 (+ - -)	S6, S1, S2	1' (+ - -)	S6', S1', S2'
2 (+ + -)	S1, S2, S3	2' (+ + -)	S1', S2', S3'
3 (- + -)	S2, S3, S4	3' (- + -)	S2', S3', S4'
4 (- + +)	S3, S4, S5	4' (- + +)	S3', S4', S5'
5 (- - +)	S4, S5, S6	5' (- - +)	S4', S5', S6'
6 (+ - +)	S5, S6, S1	6' (+ - +)	S5', S6', S1'
7 (+ + +)	S1, S3, S5	7' (+ + +)	S1', S3', S5'
8 (- - -)	S2, S4, S6	8' (- - -)	S2', S4', S6'

TABLE-1 Switching states of the individual inverters

III. DECOUPLED PWM SCHEME

The reference voltage vector to be realized by the dual inverter is shown as  $V_{ref}$  in Fig.2. It can be resolved into two equal and opposite half components as  $V_{ref}/2$  and  $-V_{ref}/2$ . The vector addition of the later and the former results in the generation of actual reference vector as:

$$V_{ref} = V_{ref}/2 - (-V_{ref}/2) \tag{1}$$

These individual reference voltages are synthesized separately by the two two-level inverters using SVPWM [19] and are depicted in Fig.3 from Fig.2 & 3 it can be identified that

$$- \tag{2}$$

The voltage vector  $OV_1$  is synthesized by inverter-1 and  $OV_2$  by inverter-2 respectively and are given as:

$$- \tag{3}$$

$$- \tag{4}$$

where  $v_{ao}, v_{bo}, v_{co}$  are three-phase pole voltages of inverter-1 and  $v_{a'o}, v_{b'o}, v_{c'o}$  are three-phase pole voltages of inverter-2 The actual vector can now obtained using the vectors defined in eqns.(3) & (4) as:

$$- \tag{5}$$

$$\tag{6}$$

$$\tag{7}$$

$$\tag{8}$$

Where  $V_{aa'}, V_{bb'}, V_{cc'}$  are the three-phase voltages of the dual-inverter fed induction motor drive.

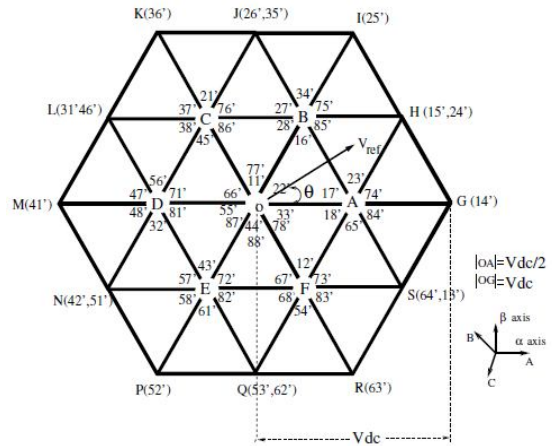

Fig. 2. Space vector locations of dual two-level inverter

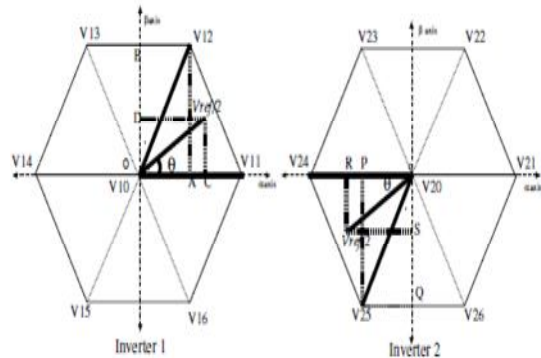

Fig. 3. Principle of decoupled PWM technique and switching voltage vector, reference voltage vector projections on  $\alpha$  and  $\beta$  axis

In Fig.3, the switching vectors  $V_{1x}, V_{2x}$  ( $x=0, 1, 2, 3, 4, 5, 6$ ) for inverter-1 & 2 can be identified and are defined as:

$$- \tag{9}$$

(10)

Where  $V_{dc}$  is the DC bus voltage and  $S_{A1}, S_{B1}, S_{C1}$  are the switching states of inverter-1 and  $S_{A2}, S_{B2}, S_{C2}$  are the switching states of inverter-2. These switching states can attain values 1 or 0 depending upon the status of the top switching device of the legs of the inverters. If the top switching device of the inverter is on, it is '1' else '0'.

The reference voltage vector ( $V_{ref}$  in Fig.2) is situated at an angle  $\theta$  w.r.t the  $\alpha$ -axis. The references to the individual inverter would then be  $V_{ref}/2$  where one is at angle ' $\theta$ ' while the other is at an angle ' $180+\theta$ ' both measured w.r.t the  $\beta$ -axis (Fig.3).The respective references are synthesized by the inverters and the switching vectors for inverter-1 can be identified as  $V_{11}, V_{12}$  &  $V_{10}$  and  $V_{24}, V_{25}$  &  $V_{20}$  for inverter-2 (Fig.3)

#### IV. ANALYSIS OF CURRENT HARMONICS IN THE DUAL TWO-LEVEL INVERTER SCHEME

With the decoupled SVPWM technique, the reference vector  $V_{ref}$  is decoupled into two equal halves as described in the previous section. These space vectors are shown in Fig.3 and are said to fall in sector 1 (for inverter-1) and sector 4 (for inverter-2). With inverter-1 and 2, the space vectors  $V_{ref}/2, -V_{ref}/2$  respectively are realized in the average sense using three nearest voltage vectors of the sector in which the tip of reference vector lies. To realize  $V_{ref}/2$ , inverter-1 switches between vectors  $V_{10}, V_{11}, V_{12}, V_{17}$  with timing intervals of  $T_{10}/2, T_{11}, T_{12}, T_{17}/2$  respectively for the center-spaced PWM. Similarly, inverter-2 switches between  $V_{20}, V_{24}, V_{25},$  and  $V_{27}$  with timing intervals of  $T_{20}/2, T_{24}, T_{25},$  and  $T_{27}/2$  respectively.

A fixed Number of samples (48) are employed for the implementation of space vector modulation per cycle in the entire range of operation. The switching patterns of both the inverters is as shown in the fig (4).

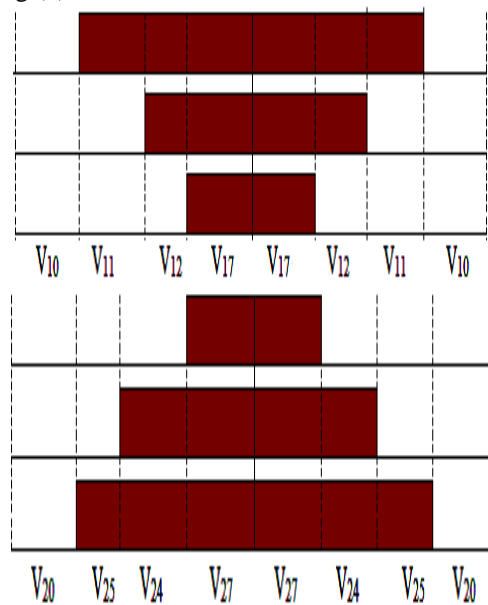

Fig (4) Switching Pattern for Inverter 1 and Inverter 2

The actual reference voltage vector (Fig.3) that is at an angle of  $\theta$  w.r.t the  $\alpha$ -axis can be resolved into two components along the  $\alpha$  &  $\beta$  - axes as OC and OD respectively. Similarly, the eight switching vectors of the inverter can also be split into the  $\alpha$  &  $\beta$  components. For instance, for the situation depicted in Fig.3, if the switching vector  $V_{12}$  is used, it has components OA and AB along the  $\alpha$  &  $\beta$  - axes respectively (applicable to inverter-1). Hence, the voltage vectors can be identified along the  $\alpha$  &  $\beta$  - axes as AC and DB respectively. Similarly, for inverter-2, the actual reference voltage vector will have the components as OR & OS and the switching vector ( $V_{25}$ ) will have OP & OS as the components

along the  $\alpha$  &  $\beta$  - axes and therefore the error voltage vectors can be identified as PR and SQ respectively along the  $\alpha$  &  $\beta$  - axes (Fig.3). The Harmonic content in the three phase currents of the induction motor is analyzed along these components with  $\alpha$  &  $\beta$  -axes. The total content of harmonics in the three phases of the motor will be modified with predominant change in the modulation index of the so connected inverters.

#### V. RESULTS & DISCUSSIONS

The dual two-level inverter with decoupled SVPWM switching scheme feeding power to open end winding induction motor drive is simulated using Matlab/SIMULINK simulation software. Then the results are verified experimentally. A DC-bus voltage of 200 volts is chosen to run the drive and V/f control is maintained in the entire speed range of the induction motor. A total of 48 samples is chosen in the entire work covering one cycle of the output voltage, irrespective of the modulation index of the drive (speed of the motor).

The gating pulses of the top switching devices of the individual inverters (depicting the timings  $T_{ga}, T_{gb}, T_{gc}$  for inverter-1 and  $T_{ga'}, T_{gb'}, T_{gc'}$  for inverter-2) are shown in Fig.5. The three phase pole voltages of the individual inverters will be a replica of the gating pulses shown in Fig.6 except for their voltage levels.

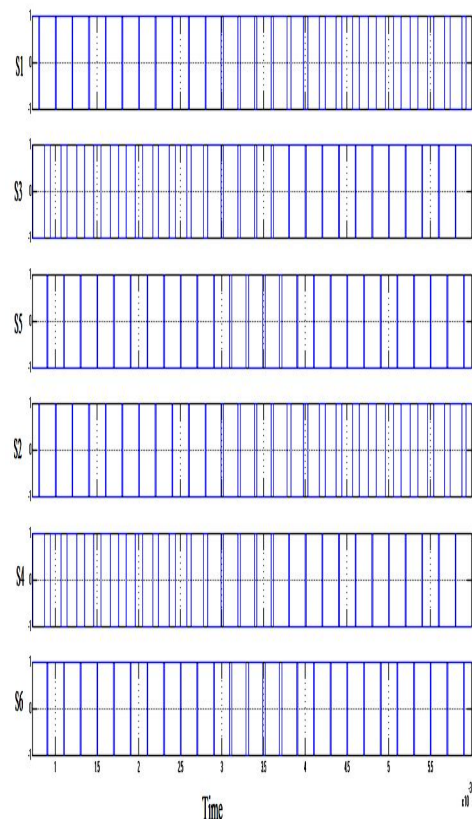

Fig (5) Gating Pulses for Inverter-1( $T_{ga}, T_{gb}, T_{gc}$ ) and Inverter- 2( $T_{ga'}, T_{gb'}, T_{gc'}$ ) for the modulation index 0.4

Here, the modulation index is defined as the ratio of the length of the reference space vector ( $V_{ref}$ ) and the DC-bus voltage ( $V_{dc}$ ).The experimentally obtained a-phase pole voltages of the two inverters, difference in a-phase pole voltages, motor a-phase voltage and the motor a-phase no-load current for a modulation index of 0.4 are as shown in the fig(6).

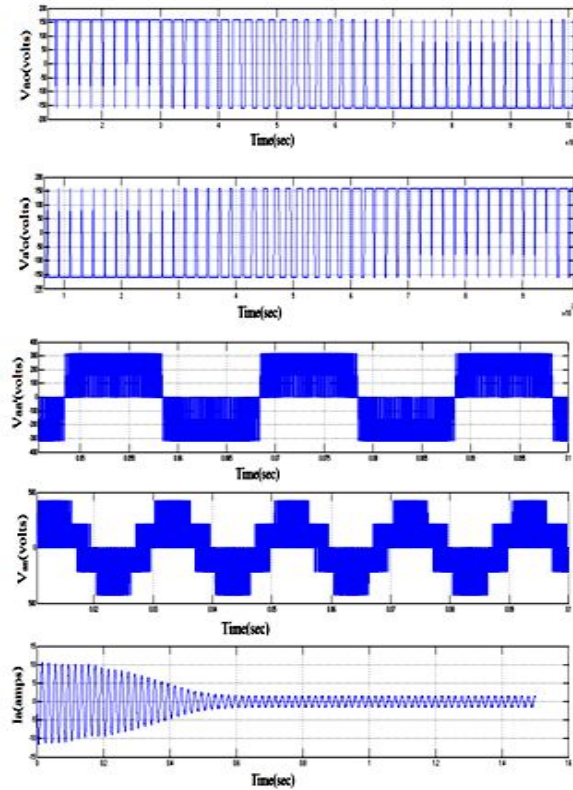

Fig (6) .Simulated pole voltages of inverter-1 and inverter-2 (Top 2 traces), Difference in a-phase pole (Vaa) voltages (3rd trace), a-phase motor phase voltage (4th trace), motor a-phase current (5th trace), for a modulation index of 0.4

The comparison in terms of harmonic content for both the cases when the motor is fed by single inverter and dual inverters is done by the total harmonic distortion along with the respective change in the corresponding modulation index. For instance the simulated results of harmonic distortion for both the cases for a modulation index of 0.4 are as shown in fig (7).

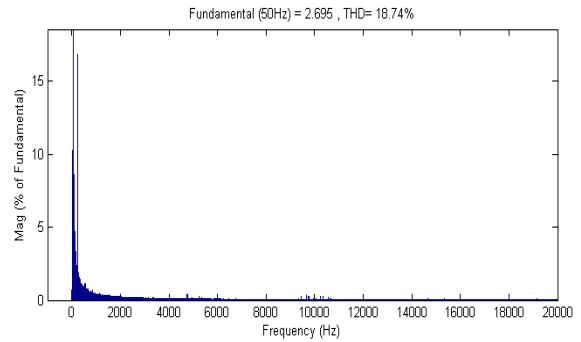
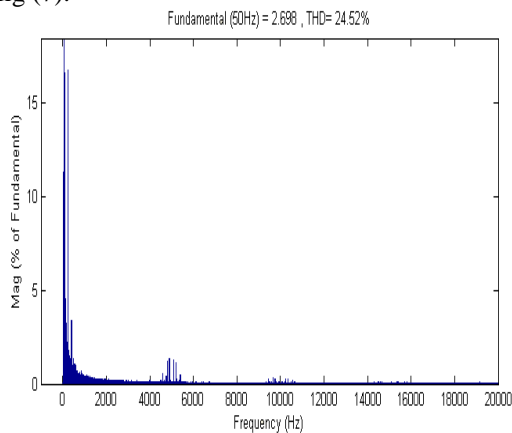

Fig (7) Simulated Results Of %THD for single inverter fed (Top trace) and dual inverter fed (Bottom trace) Induction motor drive for a modulation index of 0.4

Various changes in the %THD at different levels of Modulation index are presented in table (2).With this it is reiterated that as the modulation index increases, the harmonic content in the motor phase currents is reduced.

S.No	Operating Frequency	Modulation Index	Single Inverter Fed Induction motor drive		Dual Inverter Fed Induction Motor Drive	
			Phase Current ( $I_a$ )		Phase Current ( $I_a$ )	
			Fundamental magnitude	%THD	Fundamental magnitude	%THD
(1)	50	0.2	4.142	26.52	4.121	20.18
(2)	50	0.4	2.698	24.41	2.695	18.74
(3)	50	0.75	1.478	19.16	1.472	15.39
(4)	50	0.9	3.482	6.77	3.481	5.49

Table (2) Total Harmonic Distortion of line currents of the induction motor for different modulation index

## VI. CONCLUSION

The dual two-level inverter is capable of generating three level output voltage using the decoupled SVPWM scheme. The amount of harmonic content in the motor phase currents when error voltage between the reference voltage vector and the actual voltage vectors applied by the individual inverters is identified using the procedure proposed in this paper. The rms value of this harmonic content is decreasing with the increase in the modulation index of the dual-inverter feeding the open-end winding induction motor.

## REFERENCES

- [1] R.M. Green and J.T. Boys, "Implementation of Pulse width Modulated Inverter Modulation Strategies", *IEEE Trans. on Ind. Appl.* Vol.IA-18, No.2, Mar/Apr.1982, pp.138 - 145.
- [2] J. Holtz, "Pulse width modulation- A survey", *IEEE Trans. on Industrial Electronics*, Vol. 30, No. 5, Dec 1992, pp. 410-420.
- [3] D. G. Holmes, "The significance of Zero-Space Vector placement for Carrier-based PWM schemes", *IEEE Trans. on Ind. Appl.*, vol.32, No.5, Sept-Oct 1996, pp. 1122-1129.
- [4] Vladimir Blasko, "Analysis of a Hybrid PWM based on Modified Space-Vector and Triangle-Comparison

- Methods”, *IEEE Trans. on Ind. Appl.*, Vol.33, No.3, May/June, 1997, pp. 756-764.
- [5] G.Narayanan, Di Zhao and Harish K.krishnamurthy, “Space vector based hybrid PWM technique for reduced current ripple”, *on Ind. Electronics*, Vol.55, No.4, April 2008, pp.1614 - 1627.
- [6] V.T.Somasekhar, K.Gopakumar, A.Pittet and V.T.Ranganathan, “PWM inverter switching strategy for a dual two-level inverter fed open end winding induction motor drive with a switched neutral”, *IEE Proc. Of Electr. Power Appl.*, vol.149, No.2, March 2002, pp.152-160.
- [7] M. R. Baiju, K. K. Mohapatra, R. S. Kanchan and K. Gopakumar, “A Dual Two-level Inverter Scheme with common Mode Voltage Elimination for an Induction Motor Drive”, *IEEE Trans. on Power Electronics*. Vol.19, No.3, May 2004, pp.794-805.
- [8] R.S.Kanchan, P.N.Tekwani, M.R.Baiju, K.Gopakumar and A.Pittet, “Three-level inverter configuration with common-mode voltage elimination for induction motor drive”, *IEE Proc. of Electr. Power Appl.*, Vol.152, No.2, March-2005, pp. 261-270
- [9] S.Srinivas and V.T.Somasekhar, “A New Alternate-Inverter PWM Switching Strategy for reducing the Common-mode Voltages for a Dual-Inverter fed Open-end winding Induction motor Drive”, *Conf. Proc. IPEC-2005*, Niigata, Japan, pp.1460-1465.
- [10] V.T.Somasekhar, S.Srinivas & K.Kranti Kumar, “Effect of Zero-Vector Placement in a Dual-Inverter fed Open-end winding Induction Motor Drive with a Decoupled Space Vector PWM Strategy” *IEEE Trans. On Indus. Electronics*, Vol.55, No.6, June-2008, pp.2497-2505.

