

July 2013

## INLINE ELASTICITY MEASURE OF TEXTILE USING ANN

K V. SANTHOSH

*Department of Electrical Engineering, National Institute of Technology Silchar, India,*  
kv.santhu@gmail.com

NAMRATHA S N

*Department of Electrical Engineering, National Institute of Technology, Silchar, India,*  
namrathans@gmail.com

ANJANA PARUA

*Department of Instrumentation, BMSCE, Bangalore, India, anjana.parua@gmail.com*

Follow this and additional works at: <https://www.interscience.in/ijeee>



Part of the [Power and Energy Commons](#)

---

### Recommended Citation

SANTHOSH, K V.; S N, NAMRATHA; and PARUA, ANJANA (2013) "INLINE ELASTICITY MEASURE OF TEXTILE USING ANN," *International Journal of Electronics and Electrical Engineering*: Vol. 2 : Iss. 1 , Article 6.

DOI: 10.47893/IJEEE.2013.1061

Available at: <https://www.interscience.in/ijeee/vol2/iss1/6>

This Article is brought to you for free and open access by the Interscience Journals at Interscience Research Network. It has been accepted for inclusion in International Journal of Electronics and Electrical Engineering by an authorized editor of Interscience Research Network. For more information, please contact [sritampatnaik@gmail.com](mailto:sritampatnaik@gmail.com).

# INLINE ELASTICITY MEASURE OF TEXTILE USING ANN

<sup>1</sup>SANTHOSH K V, <sup>2</sup>NAMRATHA S N & <sup>3</sup>ANJANA PARUA

<sup>1</sup>Department of Electrical Engineering, National Institute of Technology, Silchar, India

<sup>2&3</sup>Department of Instrumentation, BMSCE, Bangalore, India

E-mail : kv.santhu@gmail.com, namrathans@gmail.com

**Abstract-** In this paper, we propose a technique to measure the Elasticity Modulus of the textile material using flex LVDT. Elasticity modulus is measured indirectly by measuring stiffness of the material first. The material whose stiffness is to be measured is subjected to a known force and the deflection caused in the material due to applied load is measured using the LVDT. Here the whole measurement is done dynamically without halting the manufacturing line of process. The output of LVDT is AC voltage. AC-DC converter is used to convert the AC output voltage of LVDT to DC output voltage. This is cascaded to the ANN block programmed on the LabVIEW platform. The results show that the proposed technique has achieved its proposed objectives.

**Keywords-**LVDT; LabVIEW; stiffness measure; Elasticity Modulus, Artificial Neural Network.

## I. INTRODUCTION

Elastic modulus is a property of the constituent material; stiffness is a property of a structure. That is, the elasticity modulus is an intensive property of the material. The stiffness of a structure is of principal importance in many engineering applications, so the modulus of elasticity is often one of the primary properties considered when selecting a material. A high modulus of elasticity is sought when deflection is undesirable, while a low modulus of elasticity is required when flexibility is needed. The measure of elasticity modulus cannot be done directly; we can find the elasticity modulus by measuring the stiffness of the material. The stiffness of a body is a measure of the resistance offered by an elastic body to deformation. For an elastic body with a single Degree of Freedom (for example, stretching or compression of a rod), the stiffness is defined as force per displacement produced by the force along the same degree of freedom [1]-[3].

There are many techniques to measure the elasticity of textile but all these are offline process and most of them derive the elasticity modulus from the material of the cloth or some are derived from tensile strength of the thread bused to spun the textile.

The present paper proposes a technique used to measure the elasticity of textile online using LVDT to measure deflection of the textile for applied load. Thus, stiffness and elasticity modulus of textile is calculated.

The paper is organised as follows: After introduction in section -I. Section-II discusses with the block diagram of the proposed technique, a brief description on sensor is given in section III. The output of the sensor is AC voltage; A brief discussion on data conversion i.e. AC-DC converter, is done in section IV, section V deals with the problem statement. Section VI deals with problem solution

and finally, results and conclusion is given in section VII.

## II. BLOCK DIAGRAM OF MEASURING SYSTEM

The block diagram representation of the proposed elasticity measuring technique is given in Fig.1

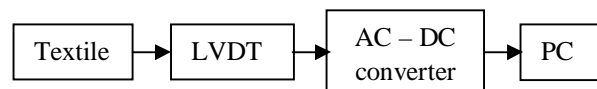

Figure. 1 Block diagram of proposed system

## III. LVDT

LVDT is used to measure linear displacement. LVDT operates on the principle of a transformer. As shown in Fig. 2, an LVDT consists of a coil assembly and a core. The coil assembly is typically mounted to a stationary form, while the core is secured to the object whose position is being measured. The coil assembly consists of three coils of wire wound on the hollow form. A core of permeable material can slide freely through the center of the form. The centre coil is the primary, which is excited by an AC source as shown. Magnetic flux produced by the primary is coupled to the two secondary coils placed on both sides of primary coil, inducing an AC voltage in each secondary coil [4]-[6].

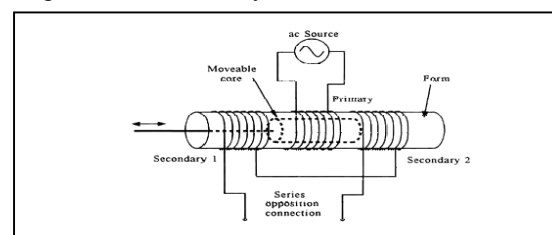

Figure 2. LVDT schematic diagram

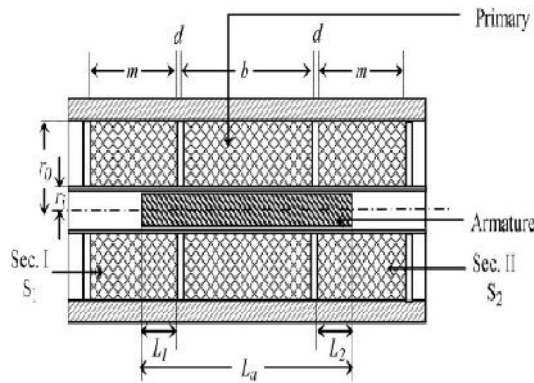

Figure. 3 Cross-section of LVDT



Figure. 4 Image of experimental setup

Figure 4 shows the experimental model used for the proposed measurement technique. The textile fabric whose stiffness or elasticity is to be measured is made to roll on to the roller. The roller are arranged in a way that the textile is held tight. Now, a weigh ball is applied on the centre of the textile causing a sag on the textile proportional to the properties of textile like stiffness and elasticity modulus.

**IV. AC-DC CONVERTER**

LVDT's output signal is converted by a 'LTC1967 true RMS to DC converter' to a DC signal that is linearly proportional to the displacement of the LVDT core. The LTC1967 is a true RMS-to-DC converter that uses an innovative delta-sigma computational technique. The benefits of the LTC1967 proprietary architecture are higher linearity & accuracy, bandwidth independent of amplitude and improved temperature behavior when compared to conventional log-antilog RMS-to-DC converters [7].

**V. PROBLEM STATEMENT**

Once signal is acquired from the AC-DC converter using DAQ card. LabVIEW is programmed to achieve the following:

- (i) Display the actual stiffness of textile used
- (ii) Display the elasticity of textile used

**VI. PROBLEM SOLUTION**

The signal from the AC-DC converter is connected to the DAQ card connected to the PC programmed using LabVIEW. LabVIEW is a graphical language used for control and automation. LabVIEW consists of two parts called the front panel and block diagram windows. The front panel to the vi consist of two numerical indicators which display the actual quantities of stiffness and elasticity modulus as shown in Fig.5.

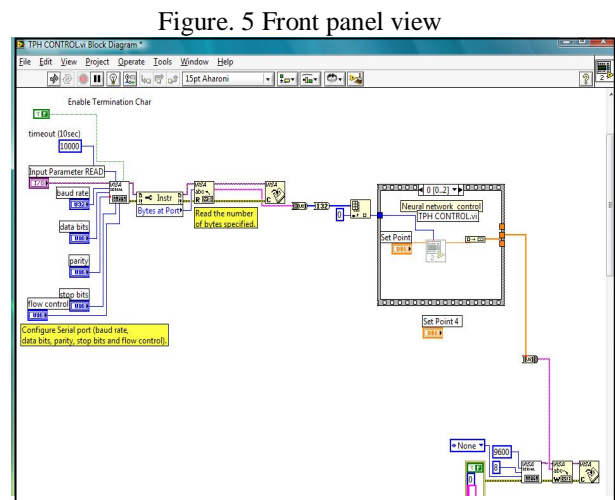

Figure. 5 Front panel view

Fig 5: Block diagram view

Fig. 6 shows the block diagram vi for the proposed technique. The block diagram consists of a DAQ input acquire corresponding to output of LVDT. This signal is further processed using the concept of neural network to display the stiffness and elasticity modulus of the textile. The neural vi is designed using the back-propagation algorithm to calculate the stiffness and elasticity modulus of textile [8]-[9].

**A: BACK-PROPOGATION ALGORITHM**

The back-propagation learning algorithm can be divided into two phases: propagation and weight update [10]-[12].

Phase 1: Propagation

Each propagation involves the following steps:

1. Forward propagation of a training pattern's input through the neural network in order to generate the propagation's output activations.
2. Backward propagation of the propagation's output activations through the neural network using the training pattern's target in order to generate the deltas of all output and hidden neurons.

Phase 2: Weight update

For each weight-synapse:

1. Multiply its output delta and input activation to get the gradient of the weight.
2. Bring the weight in the opposite direction of the gradient by subtracting a ratio of it from the weight.

This ratio influences the speed and quality of learning; it is called the learning rate. The sign of the gradient of a weight indicates where the error is increasing; this is why the weight must be updated in the opposite direction. Repeat the phase 1 and 2 until the performance of the network is good enough.

The training data for the network would be the set point data given by the user.

Table-1 summarizes the require data for training.

OPTIMIZED PARAMETERS OF THE NEURAL NETWORKS MODEL		
No of neurons in	1st layer	6
Transfer function of	1st layer	Logsig
	Output layer	linear
MSE	Training	4.42E-09
	Validation	3.265E-08
	Test	2.993E-08
R	Training	0.9999900
	Validation	0.9999960
	Test	0.9999990

Mean Squared Error (MSE) is the average squared difference between outputs and targets. Lower values are better. Zero means no error. Regression (R) values measure the correlation between outputs and targets. An R value of 1 means a close relationship, 0 a random relationship. With these details the network is trained.

The output of the neural network model is connected to the numerical indicators to display the stiffness and elasticity modulus of textile.

VII. RESULT AND CONCLUSION

The system after being trained by neural network using back-propagation was subjected to test and following results were plotted.

Parameter	Actual	Measured value
1 Stiffness	0.66 N/m	0.66 N/m
2 Stiffness	0.62 N/m	0.62 N/m
3 Stiffness	0.89 N/m	0.89 N/m
4 Stiffness	1.3 N/m	1.3 N/m
5 Elasticity Modulus of nylon	3.8 GPa	3.8 GPa
6 Elasticity Modulus of polystyrene	3.1 GPa	3.1 GPa
7 Elasticity Modulus of cotton	5.3 GPa	5.3GPa
8 Elasticity Modulus of jute	18.2 GPa	18.2 GPa

The result show that the technique produces accurate results.

REFERENCES

- [1] N.J. Abbott, "The Measurement of Stiffness in Textile Fabrics", *Textile Research Journal*, vol. 21, No. 6 pp 435-441, June 1951.
- [2] Martin Wenham, "Stiffness and flexibility", *200 science investigations for young students*, p. 126, ISBN 9780761963493, 2001.
- [3] Hugo Partsch, Bernhard partsch, Walter Braun, "Interface Pressure and Stiffness of ready made Compression Stockings: Comparison of in vivo and in vitro Measurements", *Journal of Vascular Surgery*, vol 44, Issue 4, pp 809-814, october 2006.
- [4] H. K. P. Neubert. *Instrument Transducers: An Introduction to Their Performance and Design*. 2<sup>nd</sup> edition New Delhi, India, Oxford University Press, 2003.
- [5] Bela G Liptak. *Instrument Engineers Handbook-Process Measurement and Analysis*. 4<sup>th</sup> Edition. CRC Press, 2003.
- [6] DVS Murty. *Transducers and Instrumentation*. PHI publication India, 2003.
- [7] Charles Kitchin, *Low Counts, RMS To DC Conversion Application Guide*, 2<sup>nd</sup> Edition, Analog Devices, 2000.
- [8] National Instruments, *LabVIEW help manuals*
- [9] Mahesh.L.Chugani, "LabVIEW Signal Processing", Prentice-Hall India, 1998.
- [10] Stuart Russell and Peter Norvig, *Artificial Intelligence A Modern Approach*, 3rd Edition, Prentice Hall New York, 2009.
- [11] T Poggio, F Girosi, "Networks for approximation and learning," *Proc. IEEE* 78(9), pp. 1484-1487, 1990.
- [12] Jeng-Bin Li, Yun-Kung Chung, *A Novel Back propagation Neural Network Training Algorithm Designed by an Ant Colony Optimization*, *IEEE/PES Transmission and Distribution Conference & Exhibition: Asia and Pacific Dalian, China 2005*.

