

October 2012

Design and Implementation of a Simplified Humanoid Robot with 8 DOF

Hari Krishnan R

Department of Electronics and Communication Engineering, Hindustan Institute of Technology and Science, Hindustan University, Chennai, India, hariramalayam@gmail.com

Vallikannu A. L A. L.

Department of Electronics and Communication Engineering, Hindustan Institute of Technology and Science, Hindustan University, Chennai, India, vallikannu@hindustanuniv.ac.in

Follow this and additional works at: <https://www.interscience.in/ijipvs>



Part of the [Robotics Commons](#), [Signal Processing Commons](#), and the [Systems and Communications Commons](#)

Recommended Citation

R, Hari Krishnan and A. L., Vallikannu A. L (2012) "Design and Implementation of a Simplified Humanoid Robot with 8 DOF," *International Journal of Image Processing and Vision Science*: Vol. 1 : Iss. 2 , Article 13.

Available at: <https://www.interscience.in/ijipvs/vol1/iss2/13>

This Article is brought to you for free and open access by Interscience Research Network. It has been accepted for inclusion in International Journal of Image Processing and Vision Science by an authorized editor of Interscience Research Network. For more information, please contact sritampatnaik@gmail.com.

Design and Implementation of a Simplified Humanoid Robot with 8 DOF

Hari Krishnan R & Vallikannu A. L

Department of Electronics and Communication Engineering, Hindustan Institute of Technology and Science,
Hindustan University, Chennai, India
E-mail : hariramalayam@gmail.com, vallikannu@hindustanuniv.ac.in

Abstract - This paper discusses a simplified design of Humanoid Robot with 8 DOF. The main objective is to analyze the theoretical and practical challenges involved in making it. The paper emphasis on bringing down the control complexity by reducing the number of actuators used . This in turn simplifies the entire design processes and reduces the production cost. It also describes the stability issues and different walking phases in detail. The proposed robot finds the place in between simple, miniaturized humanoids and the most advanced, sophisticated humanoids.

Keywords - Humanoid Robot, Degrees Of Freedom (DOF), Dead Weight, Centre Of Gravity, Joint Structure, Center Of Mass (COM).

I. INTRODUCTION

Humanoid Robots basically resembles human physical structure. Humanoid Robotics is an attempt to design a tool that works with human and is specifically not an attempt to recreate human being. Humanoids are expected to co-exist and work together with humans in environments which are meant for human beings. Such Robots has to interact with humans, who lives a social life. Simulation of human body gives a better idea about Humanoids.

A minimalistic approach for designing Humanoids is achieved by utilizing springs and the oscillatory motion of pendulums [1]. The robots designed with such an approach has simple control mechanisms, minimal actuation , minimal energy usage and minimal cost of production. Though robot locomotion by walking could be accomplished with these robots, it lacks areas of application due to its insane structure and design. On the other hand researches are being carried out for developing complex humanoid robots, which is similar to human beings. This could be called the complex approach. The ASMO humanoid manufactured by Honda, the WABIAN series of humanoids of Waseda University, Bonten-Maru II[2] , KHR-2 [3] , HRP2 [5] are well known for human like design. Researchers has also developed designs for humanoid robot from the perspective of DOFs and joint angles to attain Flexibility in human-like motion [2]. To achieve this they closely monitored physical structure flexibility of human and correlated it to their design.

The objective of this research is to develop a humanoid robot that could find a place in between, the robots developed using the 2 approaches. The proposed robot design emphasis on minimal computational and mechanical skill, minimal

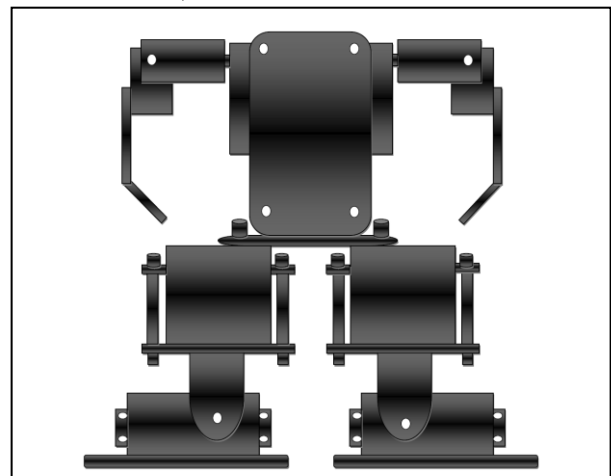

Fig. 1 : Model of Proposed Robot

actuators, simple control algorithms and electronics and most importantly it reduces production cost. The Robot has 8 DOFs, with 4 DOFs on upper body and 4 DOFs on lower body. The upper body has 2 arms with shoulder and elbow (2 DOFs each .) Lower body has 2 legs with Hip and Ankle (2 DOFs each). Design model of the proposed humanoid robot is shown in Figure 1.

II. MECHANICAL DESIGN

A. Design Considerations

The Design considerations are as follows[4].

- 1) Height of the Humanoid
- 2) Angle of body in frontal plane
- 3) Angle of body in lateral plane
- 4) Position of feet with respect to body
- 5) Position of feet with respect to floor
- 6) Speed of robot movement

B. Configuration of Links and Joints

Figure 2 shows configuration of links and joints of the proposed robot with respect to yaw, pitch and roll rotation axes. The shoulders of left and right arm of the robot has 1 DOF each with pitch rotation axis. Rotation axis of elbows are roll. At the lower limbs, the hips exhibits yaw and the ankles exhibits roll rotation axes. Figure 3 gives a detailed idea on joint structure of leg and arm of the humanoid robot. Table 1 shows a comparison of joints of proposed robot with that of

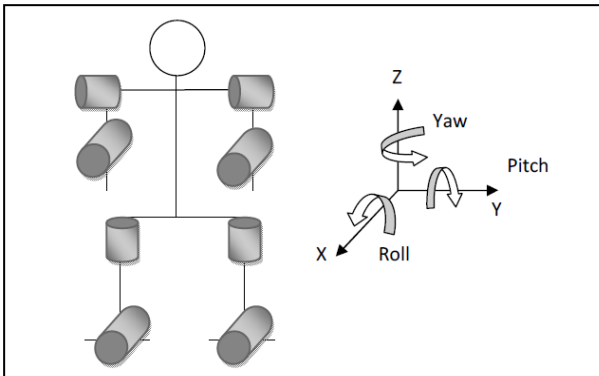

Fig. 2 : Configuration of Links and Joints

main joints of human and with that of Bonten-Maru II humanoid robot[2].

C. Lower body design

Compared to upper body, legs of Human are of less weight. This allows them to lift a foot without adjusting the upper body position. The situation of a Humanoid Robot is entirely different. The actuators on the legs of the robot makes them heavier than the upper body. So for successful locomotion, when one foot is moved, the entire upper body is leaned towards the opposite side. A biped walker undergoes 2 basic support phases. In single support phase, only one feet of the robot is on ground and in Double support phase, both the feet are on ground [4].

1) An Overview on Kinematic Model of 4 DoF Biped

Kinematic Model is the mapping of Cartesian space from Joint space. This mapping is necessary, as it determines the orientation of the foot and to calculates the positions of Centre of Mass of the links. Generalized position vector (q), generalized velocity vector (\dot{q}) and generalized acceleration vector (\ddot{q}) are the net result of the kinematic model .

The Joint angles and Link parameters of a 4 DOF biped robot is shown in Figure 4. It is a 5 links, 4 joints structure. For the sake of simplicity foot links, a_1 and a_5 are considered to be virtual links with zero mass, zero length and hence zero inertia [8]. Thus the structure under consideration becomes, a biped with 3 links and 4 joints. From figure 4, every joint i , has a unique reference name, j_i and are actuated revolute joints. a_i is the link vector connecting the joints j_{i-1} to j_i . A COM vector is a vector, b_i , specifying the COM of link i relative to j_{i-1} . Mass of link i is called m_i . Θ_i represents angle of rotation of each joints.

TABLE 1 : COMPARISON OF JOINT DISTRIBUTION

Joint	DOF at right/Left (rotation axis)		
	Human	Bonten-Maru II	Proposed Robot
Neck	3(Yaw.Pitch.Roll)	2 (Yaw.Pitch)	0
Right/Left Shoulder	3/3 (Yaw.Pitch.Roll)	2/2 (Pitch.Roll)	1/1 (pitch)
Right/Left Elbow	1/1 (Roll)	1/1 (Roll)	1/1 (Roll)
Right/Left wrist	3/3 (Yaw.Pitch.Roll)	0/0	0/0
Waist	3(Yaw.Pitch.Roll)	1 (Yaw)	0/0
Right/Left Hip	3/3 (Yaw.Pitch.Roll)	3/3 (Yaw.Pitch.Roll)	1/1 (Yaw)
Right/Left Knee	1/1 (Pitch)	1/1 (Pitch)	0/0
Right/Left Ankle	3/3 (Yaw.Pitch.Roll)	2/2 (Pitch.Roll)	1/1(Roll)

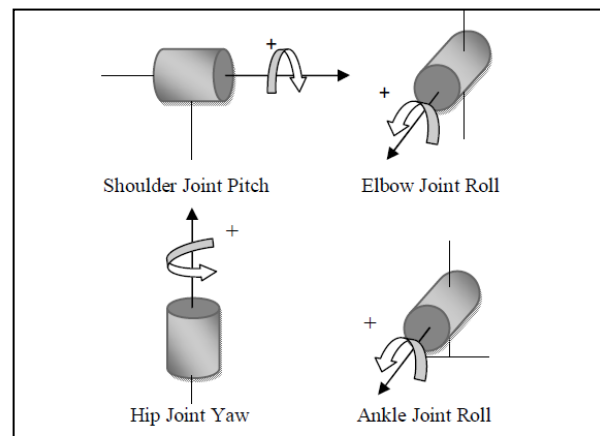

Fig. 3 : Leg and Arm Joint Structure

The orientation of the third link frame of the biped structure shown in Figure 4, can be found using

$${}^0_3R(\theta_1, \theta_2, \theta_3) = {}^0_1R(\theta_1) {}^1_2R(\theta_2) {}^2_3R(\theta_3) \quad (1)$$

The orientation of first link frame is

$${}^0_1R(\theta_1) = \begin{bmatrix} 1 & 0 & 0 \\ 0 & C_1 & -S_1 \\ 0 & S_1 & C_1 \end{bmatrix} \quad (2)$$

Where $C_1 = \cos(\theta_1)$ and $S_1 = \sin(\theta_1)$

The orientation of second link frame is

$${}^1_2R(\theta_1, \theta_2) = \begin{bmatrix} C_2 & -S_2 & 0 \\ C_1S_2 & C_1C_2 & -S_1 \\ S_1S_2 & S_1C_2 & C_1 \end{bmatrix} \quad (3)$$

and orientation of third link frame is

$${}^2_3R(\theta_1, \theta_2, \theta_3) = \begin{bmatrix} C_2C_3 - S_2S_3 & -C_2S_3 - S_2C_3 & 0 \\ C_1S_2C_3 + C_1C_2S_3 & -C_1S_2S_3 + C_1C_2C_3 & -S_1 \\ S_1S_2C_3 + S_1C_2S_3 & -S_1S_2S_3 + S_1C_2C_3 & C_1 \end{bmatrix} \quad (4)$$

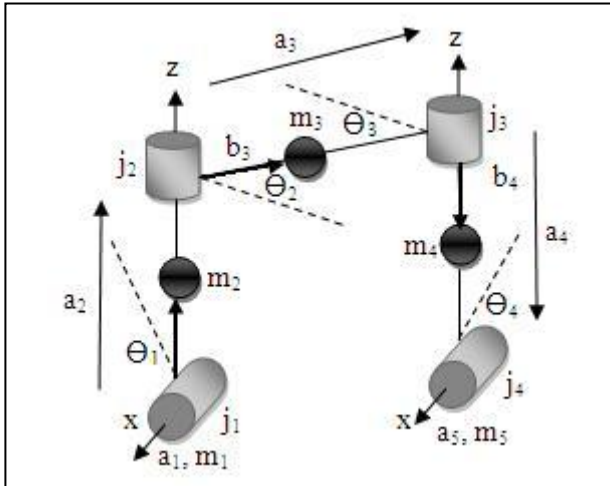

Fig. 4 : Joint angles and link parameters

The iterative equation for position of COM of link $i+1$ is

$$P_{i+1} = \begin{bmatrix} x_{i+1} \\ y_{i+1} \\ z_{i+1} \end{bmatrix} = {}^0_iR b_i + P_{j_i} \quad (5)$$

where

P_{j_i} is the position of joint i defined as

$$P_{j_i} = \begin{bmatrix} x_{j_i} \\ y_{j_i} \\ z_{j_i} \end{bmatrix} = {}^0_{i-1}R a_i + P_{j_{i-1}} \quad (6)$$

The Generalized position vector is

$$q = \begin{bmatrix} x \\ y \\ z \\ \theta \end{bmatrix} \quad (7)$$

where

$$x = [x_1 \quad x_2 \quad x_3]^T$$

$$y = [y_1 \quad y_2 \quad y_3]^T$$

$$z = [z_1 \quad z_2 \quad z_3]^T$$

which contains x, y, z co-ordinates of all COM's

$$\theta = [\theta_1 \quad \theta_2 \quad \theta_3 \quad \theta_4]^T$$

contains all joints

Generalized velocity vector

$$\dot{q} = \frac{\partial q}{\partial t} \quad (8)$$

and generalized acceleration vector

$$\ddot{q} = \frac{\partial^2 q}{\partial t^2} \quad (9)$$

2) Stability Issue and Biped Logic gait phases

Extreme care should be taken while designing the lower body of a humanoid robot. Stability is the major problem that arises during robot walking. For a biped robot to walk, it stands on single leg and swings the other leg forward. When both the legs comes to footing, in other words, if it is in double support phase, then the robot is said to be in a stable condition. To provide stability in single support phase, the concept of a moving 'Dead Weight' is utilized. According to this concept, the upper body weight is moved, so as to bring the centre of gravity on the axis of the footing leg. By this the momentum during single support phase is balanced[4].

Various phases of forward walking of the proposed humanoid robot is illustrated in Figure 5. From the Figure 5, W_M is the Weight of the upper body, θ_R and θ_L are angles around the axis of Left and Right legs respectively. Biped logic gait phases are divided into six

. While walking, these phases are continuously repeated. The phases are selected in such a way that, the robot is statically stable at the end of each phase. Each phases are described as follows:

- Phase 1- Initially the robot will be in neutral condition. The Weight will be shared among the two legs. When considering Centre of Gravity, it is maintained between the two legs. The robot is now said to be in Double support phase.

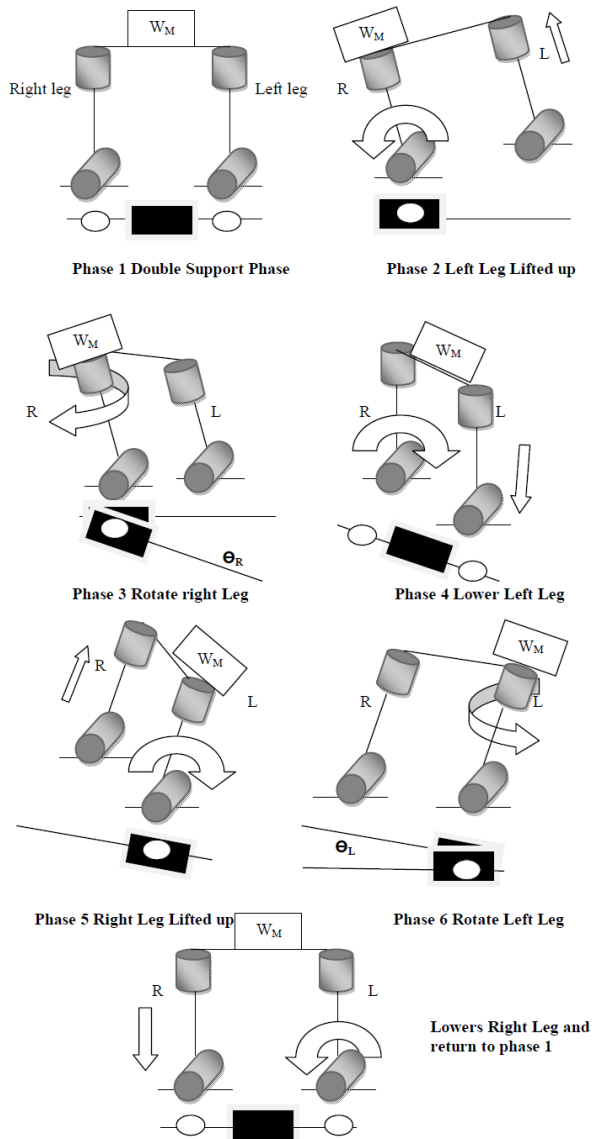

Fig. 5 : Step by step illustration of forward walking

- Phase 2 - In this phase the robot leans from left to right. The roll orientation at the ankle shifts the Weight towards right leg. As the weight is shifted towards the right leg, the centre of gravity is now

concentrated on right foot region. This phase is called Pre-swing single support phase.

- Phase 3- In this phase, the lifted left leg is made to swing in air, keeping the right feet left under the upper body. This phase is known as Swing Single support phase. This movement is achieved by Yaw orientation of the hip.
- Phase 4- As left feet reaches highest pont of its trajectory, the feet is lowered back to the ground. Now the robot is said to be in Post swing double support phase. The centre of gravity is now between the two legs.
- Phase 5- The robot leans from right to left. The Weight is shifted towards right.
- Phase 6- right leg swings in air.

After Phase 6, motion continues with a transition to phase 1 and the walking continues[3,4,6,7].

3) Structural Design

The lower limbs of the robot has 4 angular motions. I.e. 1 Yaw orientation at hip and 1 roll orientation at the ankle of each legs. In biped robots, movable range of the legs and capacity of the actuators also plays an important role[3]. So high quality motors which exhibits high torque has to be selected for practical design. Servo motors with double ball bearing and metal gears having stall Torque of 14 Kg/cm are used in the proposed design. Large foot pads of 9x6.5 cm, makes the robot more stable in one foot phase. The ankle motors are fixed on to the foot pads. The bracket that joints the hip motor and ankle motor is made of plastic . The servomotors at the hips that provide yaw orientation is designed to hang on shaft to the plastic link, that connects the two legs. While walking, to ensure that the legs doesn't hit each other, an optimal distance has been maintained.

D. Upper body Design

The upper body of the proposed robot consists of arms and torso that include 4 DOFs in total. In upper body, space for installing the controller board and electronics has been considered. The size of the torso is 9x5 cm and is made of plastic. To provide pitch orientation at the shoulders, servo motors with double ball bearing and plastic gears, having stall torque of 5.5 Kg/cm are used. Micro Servos of lesser size and stall Torque of about 1.8 Kg/cm are employed for attaining roll orientation at the elbows. Aluminum brackets are used to connect shoulder servo and elbow servo. The elbow motor is designed to hang on to the bracket, which is connected to the shoulder motor. The arm part of the robot is also made of Aluminum. No space has

been reserved for battery, as in the proposed robot external power source is used .

Figure 6 shows, the fabricated model of the robot and Figure 7 illustrates, the implemented result of various phases of robot gait

III. ELECTRICAL DESIGN

Every Robot has a number of motors to provide actuation and sensors which are controlled using a processing element. There are varieties of actuators, sensors and processing elements. In this project, two separate PIC 18F452, microcontrollers are employed as processing elements. The circuit is designed in such a way that, only one microcontroller will be active at a particular time. Controller selection switch is provided to select the microcontroller to be used The idea of implementing the design using two microcontrollers is to

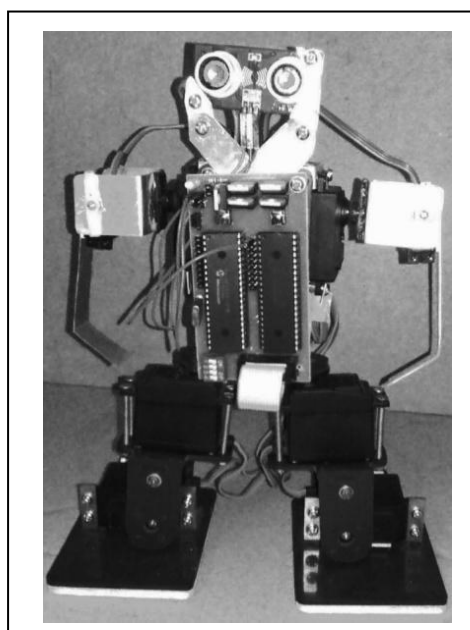

Fig. 6 : Fabricated model of the robot

increase the number of applications, that can be performed by the robot in future. By this the entire load of applications could be divided on to two microcontrollers, thus making the control part easier and simple. A 4 pin DIP switch is provided to select a particular application embedded in each controller. Due to space limitations in Main Controller Board, a Servo Extension board is provided. This board provides power and signals for the servo motors. Servo Extension Board is connected to Main controller board via FRC. An Ultrasonic Sensor Module is included for obstacle detection. This sensor module is mounted on top of the

torso so that it represents the head of the robot. The various modules used are showed in Figure 8.

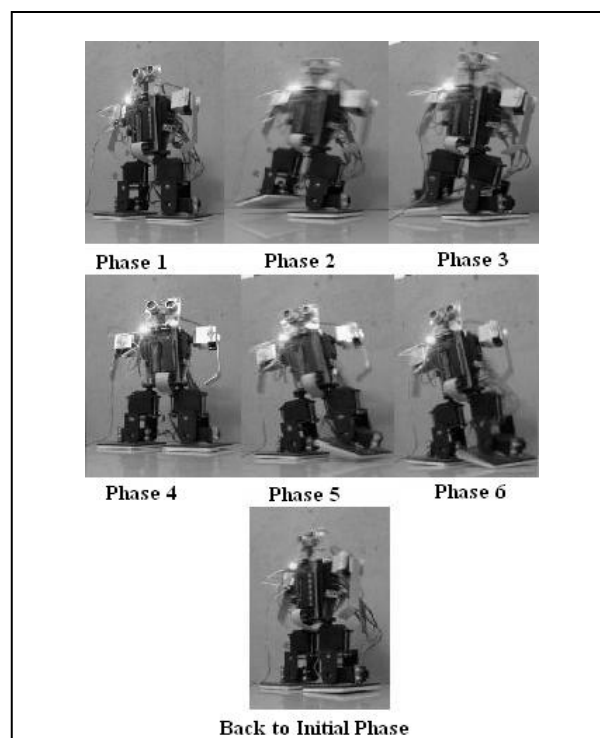

Fig. 7 : Implemented results of phases of robot gait

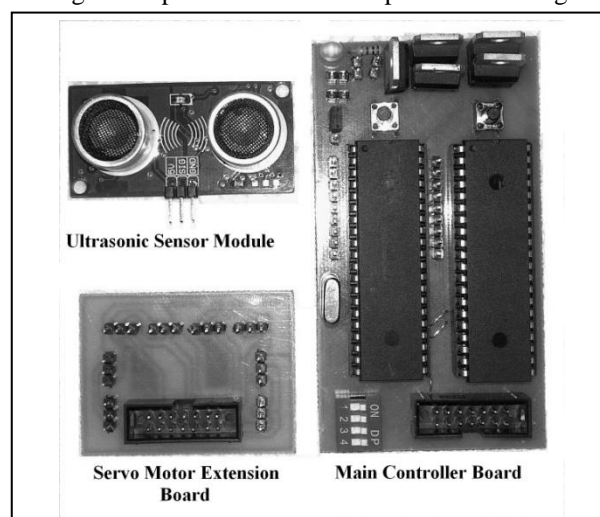

Fig. 8 : Various Modules Used

IV. FIRMWARE DEVELOPMENT

In this paper, the firmware developed to make the robot walk is discussed. All the 4 motors on the lower limbs are controlled and actuated simultaneously. Servo Motors are actuated using Pulse Width Modulation. So major aim is to program to generate PWM signal for each motors. Initially, all the motors are brought to ideal position. Now the robot is in attention posture. The first

motor which initiates the movement is serviced with on-time pulse period. During the off-time pulse period of this motor, the next motor is serviced with on-time pulse period. Likewise all the remaining motors are serviced. No special algorithms or sensors for feedback are used for balancing. So while continuous walking, after every five steps, all the motors are brought to ideal position. Figure 9 shows the flowchart for forward walking based on phases illustrated in Figure 5.

V. CONCLUSION

The reduction in number of DOF of the robot, reduces the robot development cost as well as increases robustness. The biped gait discussed is simple and could be implemented easily. As the number of DOFs increases, the complexity of mechanical design and design of control electronics becomes more complex. Making a humanoid to walk with lesser number of DOFs is a choice of interest, as it leads to energy efficient design. This paper proposes some foundations for further research and development of humanoid robots with minimum number of DOFs.

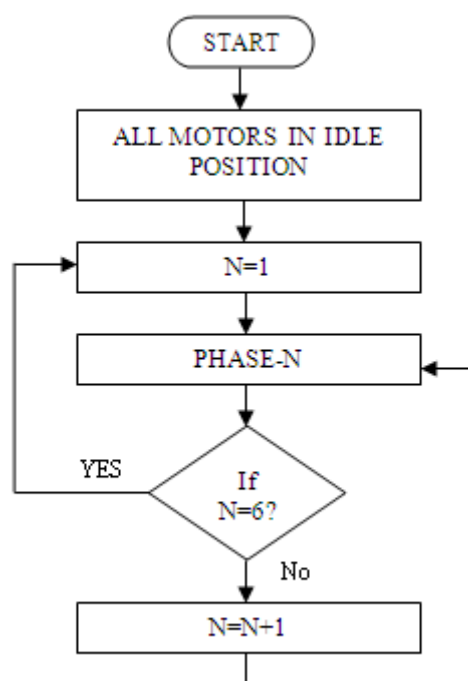

Fig. 9 : Flow Chart for forward walking

REFERENCES

- [1] Leonid Paramonov, Henrik Hautop Lund, "A Minimalistic Approach to Humanoids," in Proc. IEEE-RAS Int. Conf. on Humanoid Robots, 2001
- [2] Hanafiah Yussof, Mitsuhiro Yamano, Yasuo Nasu, Masahiro Ohka, "Design of a 21-DOF Humanoid Robot to Attain Flexibility in Human – Like Motion," in Proc 15th IEEE Int. Conf on Robot and Human Interactive Communication (RO-MAN06), 2006, pp.202-207.
- [3] Jung-Yup Kim, Ill-Woo Park, Jungho Lee, Min-Su Kim, Baek-kyu Cho, Jun-Ho Oh, "System Design and Dynamic Walking of Humanoid Robot KHR-2," in Proc IEEE Int. Conf. on Robotics and Automation, 2005, pp.1443-1448.
- [4] Appuu Kuttan K.K, Robotics, I.K International Publishing House Pvt. Ltd, India, 2007.
- [5] Kenji KANEKO1, Fumio KANEHIRO, Shuuji KAJITA, Kazuhiko YOKOYAMA, Kazuhiko AKACHI, Toshikazu KAWASAKI, Shigehiko OTA, Takakatsu ISOZUMI, "Design of Prototype Humanoid Robotics Platform for HRP," in Proc. IEEE/RSJ Int. Conf. on Intelligent Robots and Systems, 2002, pp. 2431-2436.
- [6] Andre Senior, Sabri Tosunoglu, "Robust Bipedal Walking: The Clyon Project," The 18th Florida Conf. on Recent Advances in Robotics, 2005.
- [7] Jacky Baltes, Sara McGrath, John Anderson, "Active Balancing Using Gyroscopes for a Small Humanoid Robot," in Proc. 2nd Int. Conf. on Autonomous Robots and Agents, 2004, pp. 470-475.
- [8] Jens Christensen, Jesper Lundgaard Nielsen, Mads Solver Svendsen, Peter Flakesgaard Orts, "Development, Modelling and Control of a Humanoid Robot," Technical report, Aalborg University, 2007

