

July 2013

## MAGNETIC RESONANCE COUPLING BASED WIRELESS POWER TRANSFER FOR CONTACTLESS CHARGING OF ELECTRIC VEHICLES.

SHAKTIRAJ KUMAR CHAGANTY

*Department of Electrical and Electronics Engineering, J.B. Institute of Engineering and Technology (Autonomous), Hyderabad, India., shakti456@gmail.com*

S.SIVA PRASAD

*Department of Electrical and Electronics Engineering, J.B. Institute of Engineering and Technology (Autonomous), Hyderabad, India., sshivprasadeee@gmail.com*

Follow this and additional works at: <https://www.interscience.in/gret>

 Part of the [Aerospace Engineering Commons](#), [Business Commons](#), [Computational Engineering Commons](#), [Electrical and Computer Engineering Commons](#), [Industrial Technology Commons](#), [Mechanical Engineering Commons](#), and the [Physical Sciences and Mathematics Commons](#)

---

### Recommended Citation

CHAGANTY, SHAKTIRAJ KUMAR and PRASAD, S.SIVA (2013) "MAGNETIC RESONANCE COUPLING BASED WIRELESS POWER TRANSFER FOR CONTACTLESS CHARGING OF ELECTRIC VEHICLES.,"

*Graduate Research in Engineering and Technology (GRET)*: Vol. 1 : Iss. 1 , Article 10.

DOI: 10.47893/GRET.2013.1009

Available at: <https://www.interscience.in/gret/vol1/iss1/10>

This Article is brought to you for free and open access by the Interscience Journals at Interscience Research Network. It has been accepted for inclusion in Graduate Research in Engineering and Technology (GRET) by an authorized editor of Interscience Research Network. For more information, please contact [sritampatnaik@gmail.com](mailto:sritampatnaik@gmail.com).

# MAGNETIC RESONANCE COUPLING BASED WIRELESS POWER TRANSFER FOR CONTACTLESS CHARGING OF ELECTRIC VEHICLES.

SHAKTIRAJ KUMAR CHAGANTY<sup>1</sup> & S.SIVA PRASAD<sup>2</sup>

<sup>1,2</sup>Department of Electrical Engineering, J.B. Institute of Engineering and Technology (Autonomous), Hyderabad, India.  
E-mail – <sup>1</sup>shakti456@gmail.com, <sup>2</sup>sshivprasadeee@gmail.com,

**Abstract-** The availability of a convenient charging mechanism will help greatly in dispersal of Electric Vehicles more widely. The concept of Wireless transfer of electrical energy will make this possible. The feasibility of wireless power transfer for Electric Vehicles by electromagnetic resonance coupling is investigated in this paper. The experiment is carried out on small sized antennas that can be equipped at the bottom of a vehicle. The efficiency characteristics of power transmitted wirelessly are analyzed by varying frequency of power, gap between receiving and transmitting coils and power to be transmitted. The feasibility of wireless power transfer with large air gaps and high efficiency by small sized antennas is proposed and analyzed in this paper.

**Keywords-** Contactless power transfer, magnetic resonance, coupling, battery charging.

## I. INTRODUCTION

The biggest problem that the Electrical vehicle industry is facing today is the problem of charging. Wireless power transfer is a solution to this problem. This system will enable the diffusion of Electric Vehicles (EVs) because it makes charging mechanism more convenient. Intelligent sensors are fitted in an Electric Vehicle to continuously monitor battery level and make the charging process fully automated. Electric Vehicles are automatically charged by wireless power transfer. In general, one would use a cord and plug in Electric Vehicle at home, but it is not necessary if wireless power transfer technology is used. The technology of wireless power transfer requires three main characteristics: large air gaps, high efficiency and a large amount of power. The electromagnetic resonance coupling is the only technology that meets these requirements. In this paper, the need and usefulness of wireless power transmission and the feasibility of using Electromagnetic resonance coupling as the means for wireless power transmission is investigated. There are multiple needs and uses for this technology.

## II. DESIGN OF WIRELESS POWER TRANSFER MECHANISM AND EXPERIMENTATION

To transmit power an alternating current must be passed through a closed loop coil. The alternating current will create a time varying magnetic field. The flux generated by the time varying magnetic field will then induce a voltage on a receiving coil closed loop system.

### A. RESONANT MAGNETIC COUPLING:

Magnetic coupling occurs when two objects exchange energy through their varying or oscillating magnetic fields. Resonant coupling occurs when the natural frequencies of the two objects are the same [1].

### B. BLOCK DIAGRAM OF WIRELESS POWER TRANSFER SYSTEM

The basic diagram showing the system of wireless power transfer is shown in Fig. 1. Antennas are used for transmitting and receiving the electrical energy. A high frequency power source distributes power through the transmitting antenna. Another antenna is fitted at the bottom of the Electric Vehicle which receives electric power from the transmitting antenna. This antenna is thus called receiving antenna. The transmitting antenna sends energy to a receiving antenna using electromagnetic resonance coupling wirelessly. The energy with high frequency is rectified and is used to charge the battery of the Electric Vehicle. [2-3]

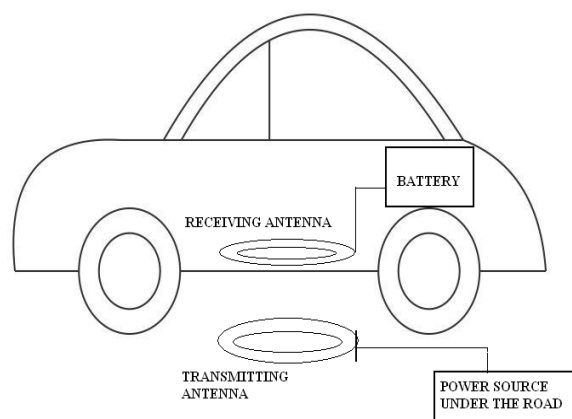

Fig. 1 Block diagram for contactless power transfer in Electric Vehicle.

In this paper, characteristics of antenna are studied because antenna characteristics decide the air gaps and efficiencies [4]. Antennas of 300mm diameter are considered so that the antenna can be fitted to the bottom of Electric Vehicles. Electromagnetic resonance couplings cannot radiate like microwave power transfer. Instead, Electromagnetic resonance couplings transfer power by connecting the electromagnetic fields of the two antennas to form a link that does not allow power to radiate outward, and thus conserves energy. The transmitting antenna is continuously fed power and this power is transferred to the receiving antenna via a wireless magnetic resonance coupling. Typical characteristics of antennas, inter-relation between air gaps, frequency and relation of power and efficiency are shown.

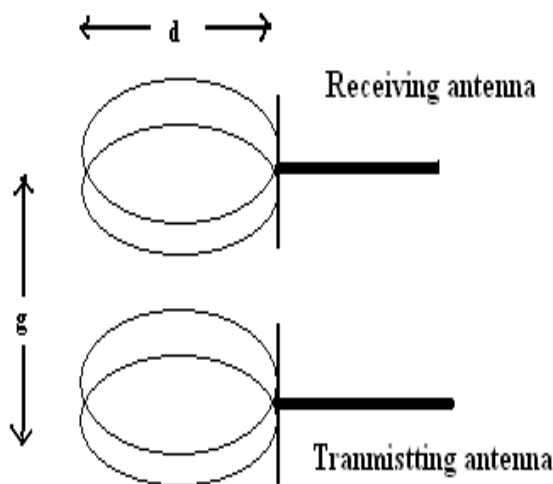

Fig. 2 Basic diagram of Antennas.

In Fig. 2: diameter ( $d$ )=300mm, air gap is represented by ( $g$ ) which is around 200mm to 400mm in our experiment.

### C. EQUIVALENT CIRCUIT

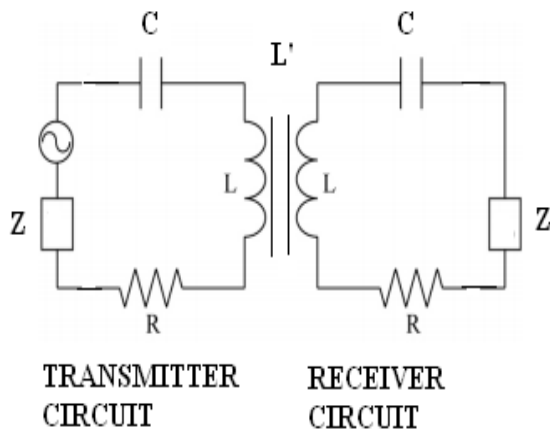

Fig. 3 Equivalent circuit of magnetic resonant coupling.

The above figure shows basic transmitter and receiver circuits. The resonance frequency can be calculated theoretically from the equivalent circuit.

### III. ADVANTAGES OF THIS SYSTEM.

#### A. Power transfer system is invisible.

The principle of Electromagnetic resonance is invisible. The necessary equipments are buried under the road. The receiving antenna is fitted under the vehicle. This facilitates invisible recharging. This system will be useful in areas where the installation of conventional overhead systems would be difficult or prohibited, such as heritage sites or parks.

#### B. Recharging on the go.

Waiting periods for charging of the battery can be avoided because high level of power transfer facilitates quicker recharging of the battery. Not just under the roads but the wireless charging equipments must also be installed all along the public parking places like offices, universities, theatres, shopping malls etc. so that when vehicles are parked they are charged automatically and ready to go long distances again [5]. This means that vehicle availability and service reliability can be ensured without employing extra fleet vehicles or batteries.

#### C. Fully Automated and Hassle Free.

Intelligent sensors fitted in the vehicle continuously detect the battery level and make the charging process fully automated. Hence the driver does not require any special training to operate Electric Vehicles.

#### D. Cuts operating costs and $\text{CO}_2$ emissions.

Since the price of fossil fuels is ever-increasing, this system will comparatively reduce the overall cost of travelling to a great extent [6]. Overall energy consumption and emissions would diminish because of the higher efficiency of electric vehicles over the entire cycle as energy is not consumed while the vehicle is stationary, unlike internal combustion engines which consume fuel while idling. In addition, regenerative braking avoids wastage of energy. The transportation system will be totally pollution free. Not just electric vehicles but wireless electricity makes everyday products more convenient, reliable, and environmentally friendly. With advancements in wireless power transfer technologies; cell phones, game controllers, laptop computers, mobile robots, will be capable of re-charging themselves without ever being plugged in [7].

### IV. EXPERIMENTAL RESULTS

The experiment is conducted by taking two coils. The two transmitting and receiving coils are kept at a fixed air gap and by changing the frequency, the power at the receiving coil is continuously measured with a wattmeter. The air gap is fixed at 100mm. The frequency at the start of the experiment is 8MHz. At this frequency, no significant power is observed in the wattmeter connected to the receiver coil i.e. no

significant power is transmitted. As the frequency of power supply is increased, the wattmeter reading also increases and reaches a maximum value at a particular frequency which is the resonant frequency of the two coils. From the oscilloscope, the resonance frequency is noted as 11.2MHz [8-9]. At this frequency, the power transfer between the coils is maximum and the efficiency of power transfer is found to be 95.8%. As the frequency is further increased the wattmeter reading connected to the power receiving coil first falls and then rises again to reach its maximum value. This is second resonant frequency. The second resonant frequency from the oscilloscope is noted as 13.1MHz. The graph of efficiency of power transmission [%] vs. frequency is plotted and is shown in Fig. 4.

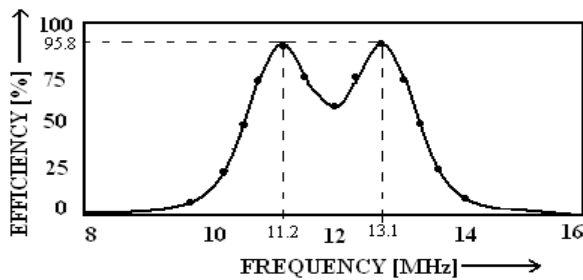

Fig. 4 Efficiency vs. Frequency at g= 100mm.

The same experiment is repeated by changing the air gap between the transmitting and receiving coils to 200mm [10]. A graph of – efficiency of power transmission vs. frequency is drawn. It is found that the resonant frequency shifts towards right i.e. the resonant frequency increases. The resonant frequency from the oscilloscope is noted as 12.0MHz. Resonance occurs only at one frequency. Hence, the number of frequencies at which resonance occurs reduces from two to one at air gap of 200mm. The graph obtained is shown in Fig. 5.

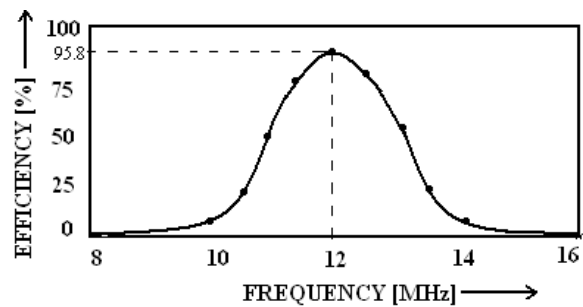

Fig. 5 Efficiency vs. Frequency at g= 200mm.

Though the resonant frequency values have changed with change of air gap between the coils, the efficiency of power transfer remains constant at 95.8%. But, when experiment is conducted by increasing the air gap beyond 200mm, the amount of power transferred is reduced. Beyond air gap of 200mm, the longer the air gaps become, the more efficiency is lost [11]. The relation between maximum efficiency and airgap is shown in Fig. 6.

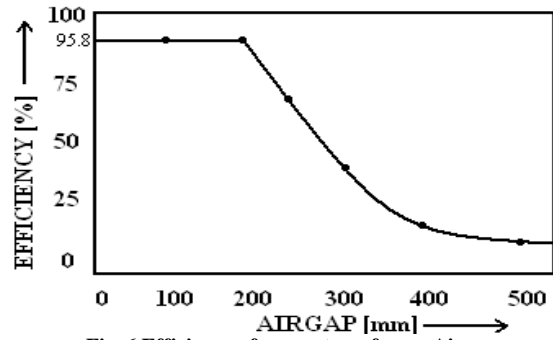

Fig. 6 Efficiency of power transfer vs. Air gap.

Theoretically, the efficiency of power transfer does not depend on the amount of power. Therefore, the efficiencies should be constant. Experimental verification is needed, however, because of the effect of heat etc. is not known until the experiment is practically performed. The air gap is 200mm and the frequency is set to resonant frequency of 12.0MHz for maximum efficiency as obtained earlier in above experiment by the Fig.- 5. The experiment is performed by steadily increasing the power to be transmitted. Wattmeters are connected across transmitting as well as receiving coils. By increasing the power in steps of 20W, both wattmeter readings are noted. The power is changed in equal steps from 5W to 100W and efficiency of power transmission is measured at every step from the readings of transmitted power and received power. In this case, when the input power is 100.0W, the received power 95.8W is recorded. Hence, the efficiency of power transmission is 95.8% and is found to be constant. Efficiency does not depend on amount of power transferred. The graph plotted between efficiency of power transmission and amount of power transmitted is shown in Fig. 7.

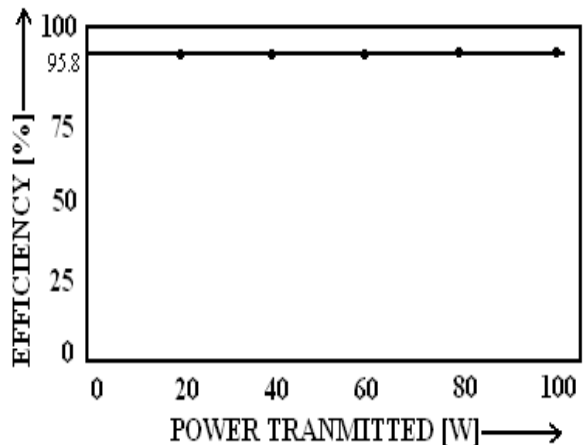

Fig. 7 Power transmitted vs. efficiency.

## V. CONCLUSION

The feasibility of wireless power transmission through Electromagnetic resonance coupling is investigated in this paper. This consists of using a transmitting and receiving coils as the coupling

antennas. The antenna's size is small enough to be equipped to the bottom of the Electric Vehicle. The efficiency characteristics of power transmitted under variable frequency, air gaps and power are determined. By increasing the length of air gap between transmitting and receiving coils from 100mm to 200mm, the number of frequencies at which resonance occur changes from two to one. The maximum efficiencies are constant for any air gap less than 200mm. Beyond 200mm, the longer the air gaps become, the more the efficiency falls. Characteristics of efficiency at variable powers are experimentally found to be same. The efficiency is found to be 95.8% at any resonant frequency. Hence, magnetic resonance coupling based wireless power transfer for contactless charging of electric vehicles is very much feasible. This technology can be built all along the existing roadway systems to charge an electric vehicle safely and efficiently.

### ACKNOWLEDGMENT

Authors are deeply indebted to the Management & Principal of J.B.Institute of Engineering and Technology (Autonomous) and also Mr. S. Yoganand, General Manager at KMC, Car Service Centre, Hyderabad for their co operation during this research work.

### REFERENCES

- [1] Koh Kim Ean "Novel band-pass filter model for multi-receiver wireless power transfer via magnetic resonance coupling and power division" Wireless and Microwave technology conference, IEEE, Date of Conference: 15-17 April 2012, Pages 1-6.
- [2] Chwei-Sen Wang, Stielau O.H., Covic G.A "A study of charging control of lead-acid battery for electric vehicles" IEEE transactions on industrial electronics, 2000, Pages 135 – 140, Vol.1
- [3] Chan H.L. "A new battery model for use with battery energy storage systems and electric vehicles power systems". Power Engineering Society, IEEE, Vol. 1, Pages: 470-475.
- [4] TakehiroImura, Hiroyuki Okabe, Toshiyuki Uchida, Yoichi Hori "Study on Open and Short End Helical Antennas with Capacitor in Series of Wireless Power Transfer using Magnetic Resonant Couplings". Industrial Electronics 35<sup>th</sup> annual conference of IEEE. Date of Conference: 3-5 Nov. 2009 Pages- 3848 – 3853.
- [5] Carter R., Cruden A, "strategies for control of a battery/supercapacitor system in an electric vehicle" Date of Conference: 11-13 June 2008, Vol. 1 Page(s): 727 – 732.
- [6] Philippe Crist "Electric Vehicles Revisited – Costs, Subsidies and Prospects" Discussion Paper 2012-03, International Transport Forum at OECD, Paris.
- [7] www.witricity.com
- [8] Nuri TEMÜRLenk, "Investigation of maximum wireless power transfer conditions in the near field"- thesis submitted for fulfillment of MS in Electrical and Electronics Engineering in Yeditepe University 2010.
- [9] Madawala, Thrimawithana, "Bidirectional Inductive Power Interface for Electric Vehicles in V2G Systems" IEEE transactions on Industrial Electronics, Date of Publication: Oct. 2011 Volume: 58 , Issue 10, Pages 4789 - 4796.
- [10] Aristeidis Karalis, J.D. Joannopoulos and Marin Soljačić, "Efficient wireless non-radiative mid-range energy transfer," Annals of Physics, Volume 323, Issue 1, January 2008, Pages 34-48, January Special Issue 2008.
- [11] Chunbo Zhu, Kai Liu, Chunlai Yu, Rui Ma, Hexiao Cheng "simulation and experimental analysis on wireless energy transfer based on magnetic resonances" Vehicle and propulsion conference, IEEE, 3-5 Sept. 2008 Conference publication. Pages – 1-4.

